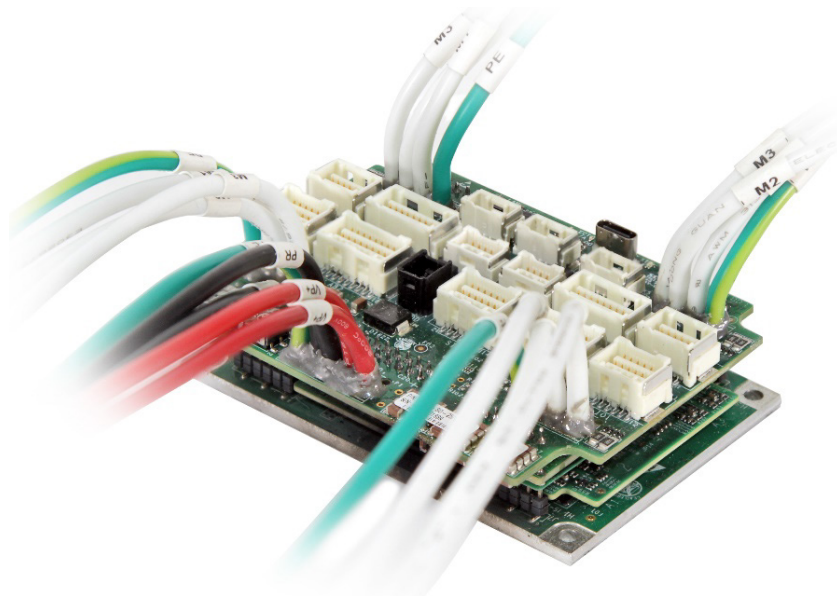
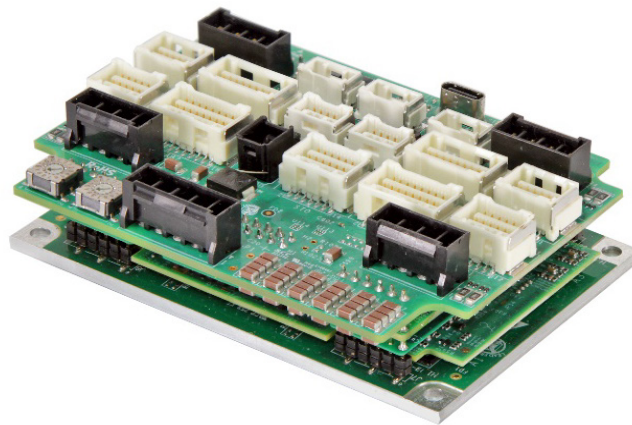


Platinum Solo Bee Quad Digital Servo Drive Installation Guide

EtherCAT



This guide is delivered subject to the following conditions and restrictions:

- This guide contains proprietary information belonging to Elmo Motion Control Ltd. Such information is supplied solely for the purpose of assisting users of Elmo’s servo drive(s) in their installation.
- The text and graphics included in this manual are for the purpose of illustration and reference only. The specifications on which they are based are subject to change without notice.
- Elmo Motion Control and the Elmo Motion Control logo are trademarks of Elmo Motion Control Ltd.
- Information in this document is subject to change without notice.



Elmo Motion Control and the Elmo Motion Control logo are registered trademarks of Elmo Motion Control Ltd.



EtherCAT® and Safety over EtherCAT® are registered trademarks and patented technologies, licensed by Beckhoff Automation GmbH, Germany.



EtherCAT® Conformance tested is a registered trademark and patented technology, licensed by Beckhoff Automation GmbH, Germany.

Document no. MAN-P-SOLBEQUAIG-EC (Ver. 3.003)

Copyright © 2024

Elmo Motion Control Ltd.

All rights reserved.

Revision History

Version	Date	Version	Date	Update
Ver. 1.000	Oct 2019	Ver. 2.004	Aug 2021	
Ver. 1.001	Jan 2020	Ver. 2.005	Nov 2021	
Ver. 1.002	Mar 2020	Ver. 2.006	Mar 2022	
Ver. 1.003	July 2020	Ver. 2.007	Apr 2022	
Ver. 2.000	Oct 2020	Ver. 2.008	Jan 2023	
Ver. 2.001	Nov 2020	Ver. 3.000	Aug 2023	
Ver. 2.002	Dec 2020	Ver. 3.001	Sept 2023	
Ver. 2.003	Mar 2021	Ver. 3.002	Nov 2023	Updated “Maximum output voltage” in Chapters 4.2.1, 4.2.2, 4.2.3
		Ver. 3.004	Mar 2024	Small change to 2.1 Warnings section

Catalog Number

PBEQ-zz-zXXX/YYYzzzQ

Family Name:

Platinum Quartet
(4 drives or 6 drives)
motion & servo package

Mounting Version:

S — 4-Axis SOLO
I — 6-Axis SOLO

Safety Capability :

O — Hardware STO only
(SIL3,Plc,CAT3)
I — No STO

Rated Current Mode:

Blank — STD I_c/ I_p
R — Continuous Operation for T_i≤85C
P — Peak Time

Rated Voltage

Rated Continuous Current

Dual Use:

Q — Not subjected to export control according to
ECCN-3A225 (US) or
428/2009 - 3A225 (EU Dual Use)
Commutation frequency limited to 599Hz
Blank - Standard. No Commutation frequency limitation

IO Style for Regular IO:

U — 5V Logic
V — PLC SRC (High Side) or SINK (Low Side)

Encoder Port B options:

E — Encoder, Absolute, Incremental,
Digital Halls, Analog Halls,
Analog Encoder (SIN/COS)

Network:

F — EtherCAT with Switches and Ethernet
USB
RS-232 Serial Communication
G — EtherCAT with Switches and Ethernet
USB
Differential RS-232 (RS-422) Serial Communication

Cable Kit

- The following cable kits may be ordered:
 - Connector's version Catalog number: CBL-PSOLQUAKIT02 EtherCAT Cable kit
 - Wired version Catalog number: CBL-PSOLQUAKIT04 EtherCAT Cable kit

For further details, see the latest version of the MAN-P-SOLQUA-CBLKIT cable kit manual.

Chapter 1:	This Installation Guide.....	7
Chapter 2:	Safety Information	7
2.1	Warnings.....	8
2.2	Cautions.....	8
2.3	CE Marking Conformance	8
2.4	Warranty Information	8
Chapter 3:	Product Description.....	9
3.1	Accessories	9
Chapter 4:	Technical Information	10
4.1	Physical Specification.....	10
4.2	Technical Data	10
4.2.1	100V Models	10
4.2.2	200V Models	11
4.2.3	R Type Models	11
4.2.4	Control Supply.....	12
4.2.5	4-Axis & 6-Axis Motor Phase Connections	12
4.2.6	Encoder Supply.....	12
4.2.7	Product Features.....	13
4.2.7.1	General Product Features.....	13
4.2.7.2	IO Features	13
4.3	Environmental Conditions	14
4.3.1	ExtriQ Conditions	14
4.3.2	Functional Safety Standards for STO.....	15
4.4	Standards and Certifications.....	16
4.4.1	Functional Safety for STO	16
4.4.2	Electrical Safety	16
4.4.3	Electromagnetic Compatibility.....	16
4.4.4	Environmental	17
4.4.5	Other Compliant Standards.....	17
4.4.6	Dual Use	17
Chapter 5:	Installation	18
5.1	Unpacking the Drive Components.....	18
5.2	Over-Current and Short-Circuit Protection.....	18
5.3	Motor Overload Protection	19
5.4	Mounting the Platinum Solo Bee Quad	19
Chapter 6:	Connector Types, Pinouts, and LEDs.....	20
6.1	Mating Connector.....	21

6.2	Connector Locations	22
6.3	Solo Board Indicator Labelling	25
6.4	Motor Power Connector Pinouts (M11, M12, M13, M14).....	26
6.5	Main Power Connector Pinouts (P1)	26
6.6	Control Power Supply Connector Pinouts (P2).....	27
6.7	STO Connector Pinouts (J76)	28
6.8	Platinum Solo Bee Quad Status Indicator.....	29
6.9	Port A and Port B Connector Pinouts (J11, J12, J13, J14)	30
6.9.1	Port A.....	30
6.9.2	Port B.....	30
6.10	Digital I/Os, & Analog Inputs Connector Pinouts (J31, J32, J33, J34).....	32
6.11	USB 2.0 Connector Pinouts (X3)	34
6.12	RS-232/RS-422 Serial Communication Main Connector Pinouts (X4)	35
6.13	RS-422 Serial Communication Auxiliary Connector Pinouts (X5)	35
6.14	EtherCAT IN Connector Pinouts (X1)	36
6.15	EtherCAT OUT/Ethernet Connector Pinouts (X2).....	36
6.16	LAN Connector Pinouts (X6)	37
Chapter 7:	Wiring	38
7.1	Wiring Legend.....	38
7.2	The Platinum Solo Bee Quad Connection Diagrams.....	39
7.3	Wiring the Female CON CLIK-MATE Connectors	40
7.4	Motor Power (M11, M12, M13, M14) Per Axis	41
7.5	Main (P1) and Control Power (P2).....	42
7.5.1	Main Supply.....	42
7.5.2	Control Supply	42
7.5.3	Power Supply for 200V Power Rating	43
7.5.4	Power Supply for 100V Power Rating	44
7.5.4.1	Single Power Supply.....	44
7.5.4.2	Shared Supply	45
7.6	STO (Safe Torque Off) (J76) Per Axis.....	46
7.6.1	Source Mode – PLC Voltage Level	46
7.6.2	TTL Mode – TTL Voltage Level	47
7.7	Feedbacks (J11, J12, J13, J14) Per Axis	48
7.7.1	Feedback Port A	48
7.7.1.1	Incremental Encoder	48
7.7.1.2	Absolute Serial Encoder	49
7.7.1.3	Hiperface	49

7.7.2	Feedback Port B	50
7.7.2.1	Incremental Encoder	50
7.7.2.2	Interpolated Analog (Sine/Cosine) Encoder	50
7.7.3	Feedback - Hall Sensors.....	51
7.8	Digital I/Os (J31, J32, J33, J34) Per Axis	52
7.8.1	Digital IO PLC Source and Sink Mode (IO Type: V)	52
7.8.1.1	Digital Input and Output PLC Source Mode.....	52
7.8.1.2	Digital Input and Output PLC Sink Mode	53
7.8.2	Digital IO 5V Logic (IO Type: U)	54
7.9	Analog Input -Differential (J31, J32, J33, J34) Per Axis	54
7.10	Communication	55
7.10.1	USB 2.0 (X3).....	55
7.10.2	RS-422 (X4 and X5)/RS-232 (X4) Serial Communication.....	55
7.10.2.1	RS-422 (Differential RS-232) Serial Communication for both X4 and X5 Connectors.....	55
7.10.2.2	X4 RS-422 (Differential RS-232) Serial Communication	56
7.10.2.3	X4 Main RS-232 Serial Communication	56
7.10.2.4	X5 RS-422 (Differential RS-232) Serial Communication.....	56
7.10.3	EtherCAT (X1 and X2)	57
7.10.3.1	EtherCAT Connection.....	57
7.10.3.2	EtherCAT Status Indicator.....	57
7.10.3.3	EtherCAT Link Indicators.....	58
7.10.3.4	EtherCAT Address Switches	58
7.10.4	LAN Connector Pinouts (X6)	59
7.10.4.1	LAN Activity Indicator	59
Chapter 8:	Powering Up.....	60
8.1	Initializing the System.....	60
8.2	Heat Dissipation.....	60
8.2.1	Thermal Data.....	60
8.2.2	Heat Dissipation Data Per Axis	60
8.2.3	How to Use the Charts	61
Chapter 9:	Dimensions	62

Chapter 1: This Installation Guide

This installation Guide details the technical data, pinouts, and power connectivity of the Platinum Solo Bee Quad. **For a comprehensive specification and detailed description of the functions, refer to the MAN-P-Quartet Hardware Manual.**

Chapter 2: Safety Information

In order to achieve the optimum, safe operation of the Platinum Solo Bee Quad, it is imperative that you implement the safety procedures included in this installation guide. This information is provided to protect you and to keep your work area safe when operating the Platinum Solo Bee Quad and accompanying equipment.

Please read this chapter carefully before you begin the installation process.

Before you start, ensure that all system components are connected to earth ground. Electrical safety is provided through a low-resistance earth connection.

Only qualified personnel may install, adjust, maintain and repair the servo drive. A qualified person has the knowledge and authorization to perform tasks such as transporting, assembling, installing, commissioning and operating motors.

The Platinum Solo Bee Quad contains electrostatic-sensitive components that can be damaged if handled incorrectly. To prevent any electrostatic damage, avoid contact with highly insulating materials, such as plastic film and synthetic fabrics. Place the product on a conductive surface and ground yourself in order to discharge any possible static electricity build-up.

To avoid any potential hazards that may cause severe personal injury or damage to the product during operation, keep all covers and cabinet doors shut.

The following safety symbols are used in this and all Elmo Motion Control manuals:



Warning:

This information is needed to avoid a safety hazard, which might cause bodily injury or death as a result of incorrect operation.



Hot Surface Warning:

To alert against surfaces that may reach high temperatures. The heatsink and wires may reach high temperatures.



Caution:

This information is necessary to prevent bodily injury, damage to the product or to other equipment.



Important:

Identifies information that is critical for successful application and understanding of the product.

The following symbols are used in this document:



Note: Information critical to the understanding and/or operating the feature.



Tip: Information that helps understanding a feature, is good practice or a possible different way of action.

2.1 Warnings

- To avoid electric arcing and hazards to personnel and electrical contacts, never connect/disconnect the servo drive while the power source is on.
- Power cables can carry a high voltage, even when the motor is not in motion. Disconnect the Platinum Solo Bee Quad from all voltage sources before servicing.
- The high voltage products within the Platinum Line range contain grounding conduits for electric current protection. Any disruption to these conduits may cause the instrument to become hot (live) and dangerous.
- STO (Safety Capability "O") circuits are separated from power circuits by reinforced insulation. Other Control and communication level circuits are separated from power circuits by functional insulation. These circuits shall have insulation to their surroundings and other control or communication circuits based on the Working Voltage and requirements of the end use application.

2.2 Cautions

- The maximum DC power supply connected to the instrument must comply with the parameters outlined in this guide.
- When connecting the Platinum Solo Bee Quad to an approved isolated control power supply, connect it through a line that is separated from hazardous live voltages using reinforced or double insulation in accordance with approved safety standards.
- Before switching on the Platinum Solo Bee Quad, verify that all safety precautions have been observed and that the installation procedures in this manual have been followed.
- Make sure that the Safe Torque Off is operational.

2.3 CE Marking Conformance

The Platinum Solo Bee Quad is intended for incorporation in a machine or end product. The actual end product must comply with all safety aspects of the relevant requirements of the European Safety of Machinery Directive 2006/42/EC as amended, and with those of the most recent versions of standards EN 60204-1 and EN ISO 12100 at the least, and in accordance with 2006/95/EC.

Concerning electrical equipment designed for use within certain voltage limits, the Platinum Solo Bee Quad meets the provisions outlined in 2006/95/EC. The party responsible for ensuring that the equipment meets the limits required by EMC regulations is the manufacturer of the end product.

2.4 Warranty Information

The products covered in this manual are warranted to be free of defects in material and workmanship and conform to the specifications stated either within this document or in the product catalog description. All Elmo drives are warranted for a period of 12 months from the time of installation, or 12 months from time of shipment, whichever comes first. No other warranties expressed or implied — and including a warranty of merchantability and fitness for a particular purpose — extend beyond this warranty.

Chapter 3: Product Description

The Platinum Solo Bee Quad is an integrated solution delivering up to **8000 W of continuous power** in a compact package (95.0 x 72.0 x 30.3 mm or 3.74" x 2.84" x 1.19"), and designed to simply and efficiently connect Elmo's Platinum Solo Bee Quad servo drive directly to the application. The solution consists of the Platinum Solo Bee Quad together with a convenient connection interface, which either eliminates or reduces development time and resources when designing an application's PCB board.

The Platinum Solo Bee Quad, provided in the optional forms shown in Figure 1, with its advanced, high power density servo drive provides top performance, Functional Safety, advanced networking as well as a fully featured motion controller and local intelligence.

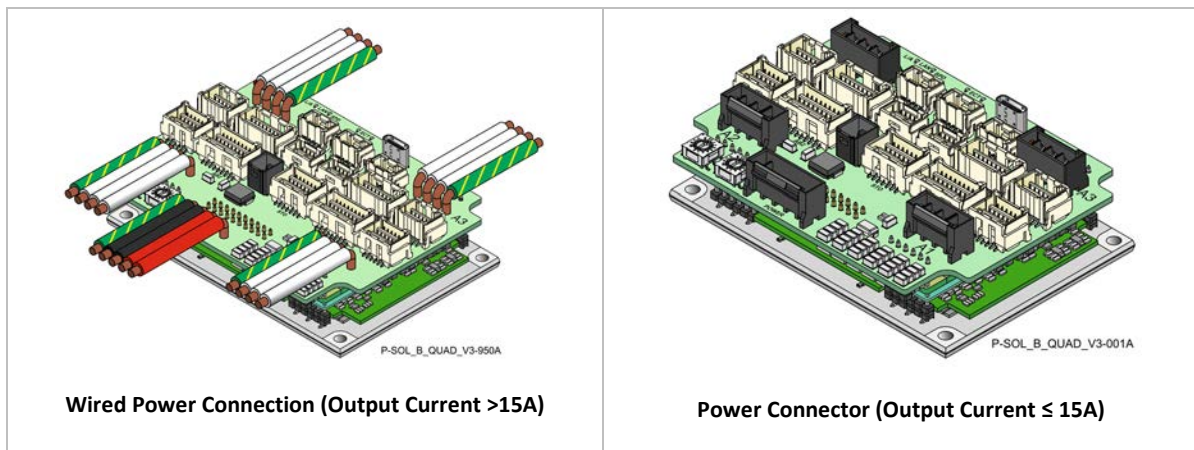


Figure 1: Platinum Solo Quad with Power Connector Options

The Platinum Solo Bee Quad is provided in the following configuration:

- **Servo drive with STO Only** – The servo drive configuration supports only STO.

The Platinum Solo Bee Quad is powered by a single 14 V – 95 V isolated DC power source (not included) and a “smart” control-supply algorithm enables the drive to operate up to 95 V with only one power supply for nonfunctional safety, with no need for a Control power supply. The Control power supply is usually required for the logic.

The drive can operate as a stand-alone device or as part of a multi-axis system in a distributed configuration on a real-time network.

The Platinum Solo Bee Quad drive is easily set up and tuned using Elmo Application Studio (EASII) software tools now available in both 32bit and 64bit versions. As part of the Platinum product line, it is fully programmable with the Elmo motion control language. For more about software tools refer to the Elmo Application Studio Inline-Help.

The Platinum Solo Bee Quad is available in a variety of options. There are multiple power rating options; 14AWG Power wires for the ‘Output Current > 15A’ Wired Power connection, two different communications options, a variety of feedback selections, and I/O configuration possibilities.

3.1 Accessories

Two types of cable kits may be ordered:

- Connector's version Catalog number: CBL-PSOLQUAKIT02 - EtherCAT Cable kit
- Wired version Catalog number: CBL-PSOLQUAKIT04 - EtherCAT Cable kit

For further details, see the documentation for the Platinum Solo Quad cable kit.

Chapter 4: *Technical Information*

4.1 Physical Specification

Feature	Units	All Types
Weight	g (oz.)	174g (6.14 oz)
Dimension	mm (in)	95 x 72 x 30.3 mm(3.74" x 2.84" x 1.19")
Mounting method		Panel Based
Interface Board LEDs		Drive Status, EtherCAT Status, EtherCAT Link In and Out, LAN Link, LAN Speed

4.2 Technical Data

The following tables describe the technical data for the Platinum Solo Bee Quad per axis.

4.2.1 100V Models

Feature	Units	1/100	3/100	6/100	10/100	15/100	25/100	P50/100
Minimum supply voltage	VDC	10						
Nominal supply voltage	VDC	85						
Maximum supply voltage	VDC	95						
Maximum continuous power output	W	70	220	440	735	1100	2000	2000
Efficiency at rated power (at nominal conditions)	%	> 99						
Maximum output voltage		Up to 96% of DC bus voltage						
Amplitude sinusoidal/DC continuous current	A	1	3	6	10	15	25	25
Sinusoidal continuous RMS current limit (Ic)	A	0.7	2.1	4.2	7.1	10	17.7	17.7
Peak current limit	A	2 x Ic						
Peak Time	Secs	Standard 3secs						Up to 30secs

Table 1: Power Rating for 100V Models

4.2.2 200V Models

Feature	Units	3/200	6/200	10/200
Minimum supply voltage	VDC	20		
Nominal supply voltage	VDC	170		
Maximum supply voltage	VDC	195		
Maximum continuous power output	W	440	880	1450
Efficiency at rated power (at nominal conditions)	%	> 99		
Maximum output voltage		Up to 96% of DC bus voltage		
Amplitude sinusoidal/DC continuous current	A	1	6	10
Sinusoidal continuous RMS current limit (Ic)	A	2.1	4.2	7.1
Peak current limit	A	2 x Ic		

Table 2: Power Rating for 200V Models

4.2.3 R Type Models

Feature	Units	R15/200	R35/200
Minimum supply voltage	VDC	20	
Nominal supply voltage	VDC	170	
Maximum supply voltage	VDC	195	
Maximum continuous power output	W	*2200	*5100
Efficiency at rated power (at nominal conditions)	%	> 99	
Maximum output voltage		Up to 96% of DC bus voltage	
Amplitude sinusoidal/DC continuous current	A	15	35
Sinusoidal continuous RMS current limit (Ic)	A	10.6	24.8
Peak current limit	A	Ic	

Table 3: Power Rating for R Type Models



Note (on current ratings): The current ratings of the Platinum Solo Bee Quad are given in units of DC amperes (ratings that are used for trapezoidal commutation or DC motors). The RMS (sinusoidal commutation) value is the DC value divided by 1.41.

Note (*): Total output power allowed for all axes up to 8000W.

4.2.4 Control Supply

Feature		Unit	Details
Control supply input voltage		V	Isolated DC source: 14 to 95
24V Control supply input power consumption	Without encoder	W	≤4
	With 4 x 300mA encoders (1.2A@5VE)	W	≤11.5

4.2.5 4-Axis & 6-Axis Motor Phase Connections


For the 4-Axis Motor connections, four Brushless motors can be connected. Each motor uses 3-Phases.

For the 6-Axis Motor connections, six DC Brush motors can be connected. Each motor uses 2-Phases.

The following table describes the basic motor connections. For details refer to the section 7.4 Motor Power (M11, M12, M13, M14) Per Axis.

PQUA_Phases	4-Axis Motors	6-Axis Motors
Axis1_M1	√	Motor 1
Axis1_M2	√	
Axis1_M3	√	
Axis2_M1	√	Motor 2
Axis2_M2	√	
Axis2_M3	√	
Axis3_M1	√	Motor 3
Axis3_M2	√	
Axis3_M3	√	
Axis4_M1	√	Motor 4
Axis4_M2	√	
Axis4_M3	√	

4.2.6 Encoder Supply

Feature	Details								
5V supply	5V ±5% Total current capability of 1200mA  Note: <table border="1" data-bbox="531 1868 1337 2031"> <thead> <tr> <th>5VE per axis</th> <th>Current per pin</th> <th>Total Current per axis</th> </tr> </thead> <tbody> <tr> <td>Pin 1</td> <td>200mA</td> <td rowspan="2">300mA</td> </tr> <tr> <td>Pin 2</td> <td>200mA</td> </tr> </tbody> </table>	5VE per axis	Current per pin	Total Current per axis	Pin 1	200mA	300mA	Pin 2	200mA
5VE per axis	Current per pin	Total Current per axis							
Pin 1	200mA	300mA							
Pin 2	200mA								

4.2.7 Product Features

4.2.7.1 General Product Features

Main Feature	Details	Presence and No.
Feedback	Standard Ports A and B feedbacks Supports Incremental encoder, Absolute serial encoders and analog encoder	√ 4 Axes x Standard Ports A and B feedbacks
Communication Option	USB	√
	EtherCAT with Address Switches	√
	LAN	√
	CAN (Available in the future)	√
	RS-232 TTL level	√
	RS-422 Main	√
	RS-422 Auxiliary	√
Analog Input	Differential ±10V or Single Ended	√ 1 per axis

4.2.7.2 IO Features

Main Feature	Details	Presence and No.
STO	TTL or PLC SRC	√ per axis
Digital Input	5V Logic or PLC SRC or PLC SINK	√ 4 per axis
Digital Output	5V logic or PLC SRC or PLC SINK	√ 2 per axis

4.3 Environmental Conditions

You can guarantee the safe operation of the Platinum Solo Bee Quad by ensuring that it is installed in an appropriate environment. Section 4.3.1 describes the extended environmental conditions. However, the Functional Safety of the ExtrlQ series servo drives is certified according to the environmental conditions in section 4.3.2.



Warning:


During operation the Platinum Solo Bee Quad becomes hot to the touch (the heatsink and wires may heat up to 85 °C). Care should be taken when handling it.

4.3.1 ExtrlQ Conditions

Feature	Operation Conditions	Range
Ambient Temperature Range		-40 °C to +70 °C (-40 °F to +158 °F)
Storage temperature		-40 °C to +85 °C (-40 °F to +185 °F)
Altitude	Non-operating conditions	Unlimited
	Operating conditions	-400 m to 12,000 m (-1312 to 39370 feet)
Maximum Humidity	Non-operating conditions	Up to 95% relative humidity non-condensing at 35 °C (95 °F)
	Operating conditions	Up to 95% relative humidity non-condensing at 25 °C (77 °F), up to 90% relative humidity non-condensing at 42 °C (108 °F)
Vibration	Operating conditions	20 Hz to 2,000 Hz, 14.6 g

4.3.2 Functional Safety Standards for STO

Functional Safety of the ExtriQ series servo drives is certified according to the following environmental conditions.

Feature	Details
Operating ambient temperature	-40 °C to +55 °C (-40 °F to +131 °F)  Remark: Functional Safety is applicable to the above operating temperature.
Storage temperature	-40 °C to +85 °C (-40 °F to +185 °F)
Maximum non-condensing humidity according to IEC60068-2-78	95%
Maximum Operating Altitude	2,000 m (6562 feet) It should be noted that servo drives capable of higher operating altitudes are available on request.
Mechanical Shock according to IEC60068-2-27	15g / 11ms Half Sine
Vibration according to IEC60068-2-6	5 Hz ≤ f ≤ 10 Hz: ±10mm 10 Hz ≤ f ≤ 57 Hz: 4G 57 Hz ≤ f ≤ 500 Hz: 5G

4.4 Standards and Certifications

4.4.1 Functional Safety for STO

Standard	Item
IEC 61800-5-2:2017	Adjustable speed electrical power drive systems – Safety requirements – Functional
EN ISO 13849-1:2015	Safety of machinery – Safety-related parts of control systems.
EN 61508-1:2010	Functional safety of electrical/electronic/programmable electronic safety-related systems
EN 61508-2:2010	Functional safety of electrical/electronic/programmable electronic safety-related systems
EN 61508-3:2010	Functional safety of electrical/electronic/programmable electronic safety-related systems

4.4.2 Electrical Safety

Specification	Details
IEC/EN 61800-5-1:2007/AMD1: 2016 IEC/EN 61800-5-1:2007/A1: 2017	Adjustable speed electrical power drive systems Part 5-1: Safety requirements – Electrical, thermal and energy
In compliance with UL 61800-5-1	Adjustable speed electrical power drive systems: Safety requirements – Electrical, thermal and energy
In compliance with CSA C22.2 NO. 274-17	Adjustable speed drives

4.4.3 Electromagnetic Compatibility

Specification	Details
EN 61800-3:2004/A1:2011	Adjustable speed electrical power drive systems Part 3: EMC requirements and specific test methods
EN 61800-5-2: 2017 Annex E	Adjustable speed electrical power drive systems Part 5-2: Safety requirements – Functional

4.4.4 Environmental

Specification	Details
IEC60068-2-78	Damp heat, steady state
IEC60068-2-6	Vibration (sinusoidal)
IEC60068-2-2	Dry heat
IEC60068-2-27	Shock
IEC60068-2-1	Cold Test

4.4.5 Other Compliant Standards

For other compliant standards refer to the

[Platinum Safety Drive Manual Section 22.5](#) or refer to the Elmo website:

<https://www.elmomc.com/capabilities/standards-compliance/platinum-family/>

4.4.6 Dual Use

No export license is required for the Platinum Line products signified with the suffix Q in the Part Number.

The operating frequency of the Platinum Line products is “factory limited” to ≤ 599 Hz, and therefore complies with the EU Dual Use Regulation 428/2009, 3A225, and the US Dual Use regulation EAR ECCN# 3A225.

This statement applies to all identical specimens and will become invalid if a change is made in the firmware.

Chapter 5: Installation

The Platinum Solo Bee Quad must be installed in a suitable environment and properly connected to its voltage supplies and the motor. A serial fuse or circuit breaker should be installed Rated for drive’s continuous RMS current rating.

5.1 Unpacking the Drive Components

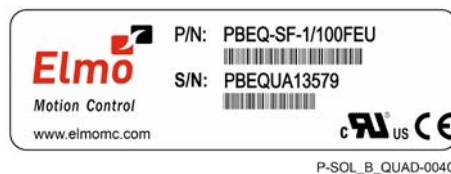
Before you begin working with the Platinum Solo Bee Quad, verify that you have all of its components, as follows:

- The Platinum Solo Bee Quad servo drive
- The Elmo Application Studio (EASII) software

The Platinum Solo Bee Quad is shipped in a cardboard box with Styrofoam protection.

To unpack the Platinum Solo Bee Quad:

1. Carefully remove the servo drive from the box and the Styrofoam.
2. Check the drive to ensure that there is no visible damage to the instrument. If any damage has occurred, report it immediately to the carrier that delivered your drive.
3. To ensure that the Platinum Solo Bee Quad you have unpacked is the appropriate type for your requirements, locate the part number sticker on the side of the Platinum Solo Bee Quad. It looks like this:



4. Verify that the Platinum Solo Bee Quad type is the one that you ordered, and ensure that the voltage meets your specific requirements.
The part number at the top provides the type designation. Refer to the appropriate part number in the section Catalog Number at the beginning of the installation guide.

5.2 Over-Current and Short-Circuit Protection

A serial fuse or circuit breaker should be installed Rated for drive’s continuous power.

PBEQ–zz-zXXX/YYzzzQ XXX = rated continues current [A]	Fuse	Circuit Breaker
1, 3, 6, 10, 15, 25 / 100V	Fast Acting Class J	DC Medium
P 50 / 100V	Fast Acting Class J	DC Medium
3, 6, 10, R15, R35 / 200V	Fast Acting Class J	DC Medium
Rated short - circuit breaking capacity 5kA		

PL/CL protection: Peak and Continues Limitation

The peak current of servo drive limit for a given application is programmed to the parameter **PL[1]** amperes.
PL[1]: Value for peak current limit protection. Please refer to the “Platinum Administrative Guide”.

5.3 Motor Overload Protection

The Platinum Solo Bee Quad supports Electronic Motor Overload protection as required by IEC-61800-5-1 with the exception of thermal memory retention and speed sensitivity.

5.4 Mounting the Platinum Solo Bee Quad

The Platinum Solo Bee Quad was designed for mounting on a surface. When integrating the Platinum Solo Bee Quad into a device, be sure to leave about 1 cm (0.4") outward from the heat-sink to enable free air convection around the drive. If the Platinum Solo Bee Quad is enclosed in a metal chassis, we recommend that the Platinum Solo Bee Quad be screw-mounted to it to help with heat dissipation. The Platinum Solo Bee Quad has screw-mount holes on each corner of the heat-sink for this purpose – see below. Use 4 x M3 x 8 mm screws to mount the Platinum Solo Bee Quad onto a surface to a force of 0.4 Nm torque for each screw.

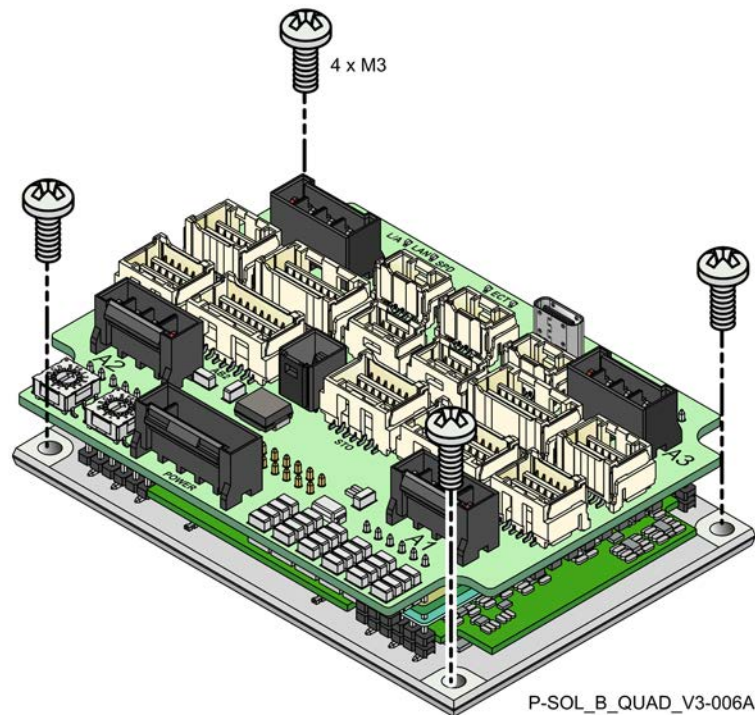


Figure 2: Mounting the Platinum Solo Bee Quad

Chapter 6: Connector Types, Pinouts, and LEDs

Throughout this document, all Ax connections refer to the specific axis “x”, numbered from 1...4.

The Platinum Solo Bee Quad has nineteen connectors (connectors' version).

Port	No. Pins	Type	Function
M1 (M11) M1, M2, M3, PE	4	3.96 mm pitch	Motor A1 phases
M2 (M12) M1, M2, M3, PE	4	3.96 mm pitch	Motor A2 phases
M3 (M13) M1, M2, M3, PE	4	3.96 mm pitch	Motor A3 phases
M4 (M14) M1, M2, M3, PE	4	3.96 mm pitch	Motor A4 phases
P1 VP+, VP+, PR, PR, PE	5	3.96 mm pitch	Power
P2 PR, VL+, VDD	2x2	2.0 mm pitch	Control Power
J76	2x7	1.5 mm pitch	STO
J11	2x9	1.5 mm pitch	Feedback Port A/B1
J12	2x9	1.5 mm pitch	Feedback Port A/B2
J13	2x9	1.5 mm pitch	Feedback Port A/B3
J14	2x9	1.5 mm pitch	Feedback Port A/B4
J31	2x6	1.5 mm pitch	I/O1
J32	2x6	1.5 mm pitch	I/O2
J33	2x6	1.5 mm pitch	I/O3
J34	2x6	1.5 mm pitch	I/O4
X3	24	USB Device Type-C	USB
X4	5	1.5 mm pitch	RS-422/RS-232 Main communication
X5	5	1.5 mm pitch	RS-422 Auxiliary communication
X6	5	1.5 mm pitch	LAN Communication
EtherCAT Version			
X1	5	Molex, 505405-0560 CLIK-Mate, 1.5 mm pitch	EtherCAT in
X2	5	Molex, 505405-0560 CLIK-Mate, 1.5 mm pitch	EtherCAT out

6.1 Mating Connector

Connector	Mating Connector Type	Mating Crimping Pins
J11, J12, J13, J14 Feedback Port A/B	CON CLIK-MATE HOUSING FE 18PIN (2X9) P=1.5 mm pitch plug	MOLEX CRIMP TERMINAL FE 24-28AWG FOR CLIK-MATE 1.5 mm
J31, J32, J33, J34 I/O	CON CLIK-MATE HOUSING FE 12PIN (2X6) P=1.5 mm pitch plug	
X4 RS-422/RS-232 Main communication	CON CLIK-MATE HOUSING FE 5PIN (1X5) P=1.5 mm pitch	
X6 LAN communication	CON CLIK-MATE HOUSING FE 5PIN (1X5) P=1.5 mm pitch	
X1, X2 IN/OUT CAN/EtherCAT Communication	CON CLIK-MATE HOUSING FE 5PIN (1X5) P=1.5 mm pitch	
X5 RS-422 Auxiliary communication	CON CLIK-MATE HOUSING FE 5PIN (1X5) P=1.5 mm pitch	
J76 STO	CON CLIK-MATE HOUSING FE 14PIN (2X7) P=1.5 mm pitch	
M11, M12, M13, M14 Motor Phases	CON HOUSING HRS DF63 FE ST 4PIN (1X4) P=3.96MM	HRS CRIMP TERMINAL FE 16- 18AWG TIN FOR DF63 3.96mm SERIES
P1 Power	CON HOUSING HRS DF63 FE ST 5PIN (1X5) P=3.96MM	
P2 Control Power	CON HOUSING HRS DF51K FA ST 4PIN (2X2) P=2MM	HRS CRIMP TERMINAL FE 22AWG FOR DF51K 2mm SERIES

6.2 Connector Locations

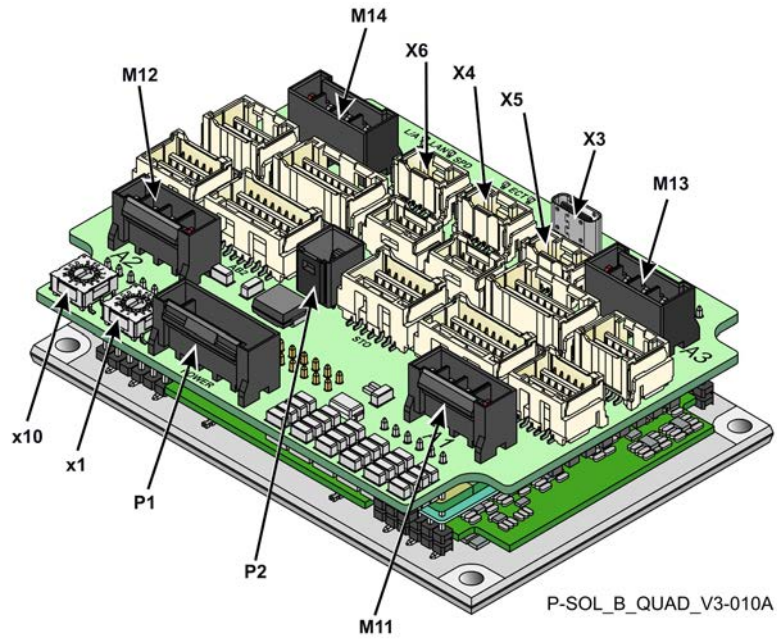


Figure 3: Horizontal Power Connector Names and Locations

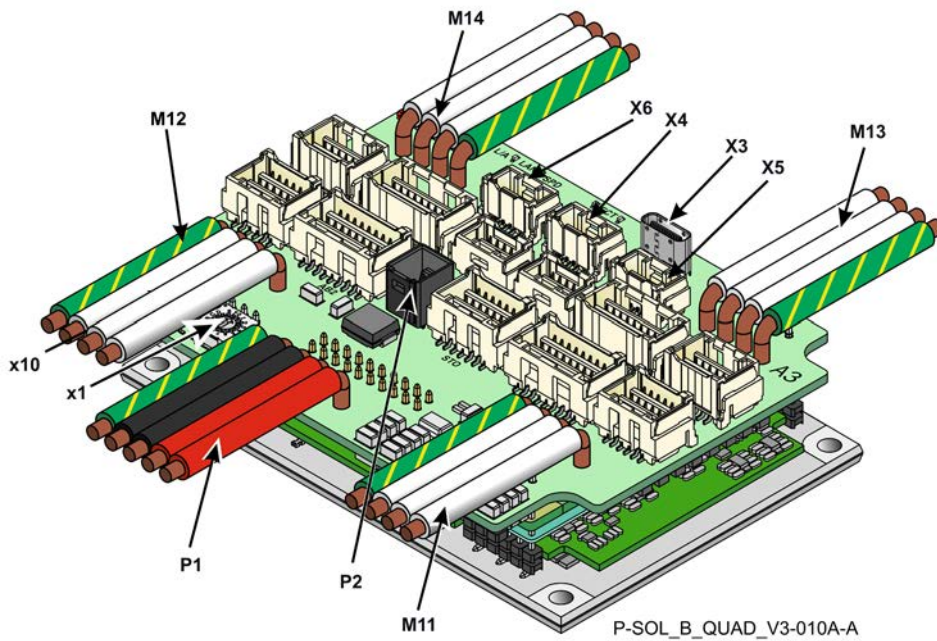


Figure 4: Wired Power Connection Names and Locations

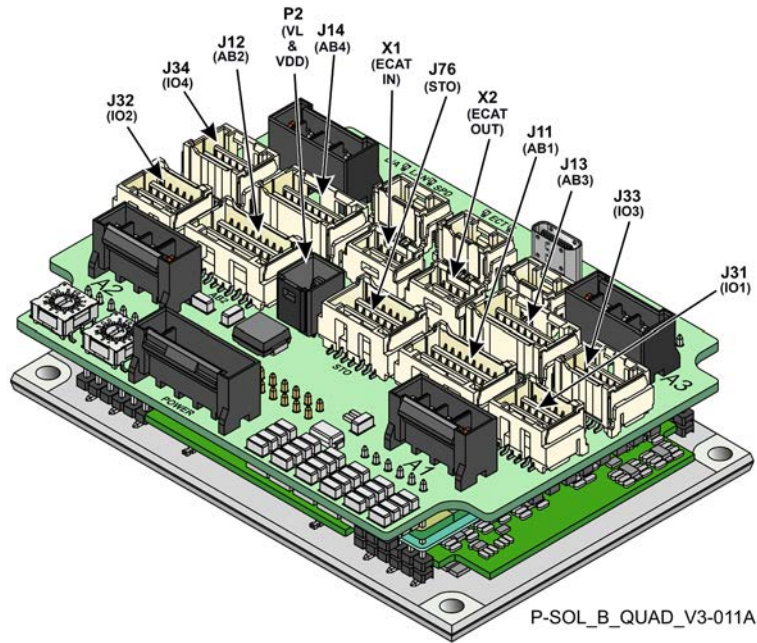


Figure 5: Connectors and Connector Locations

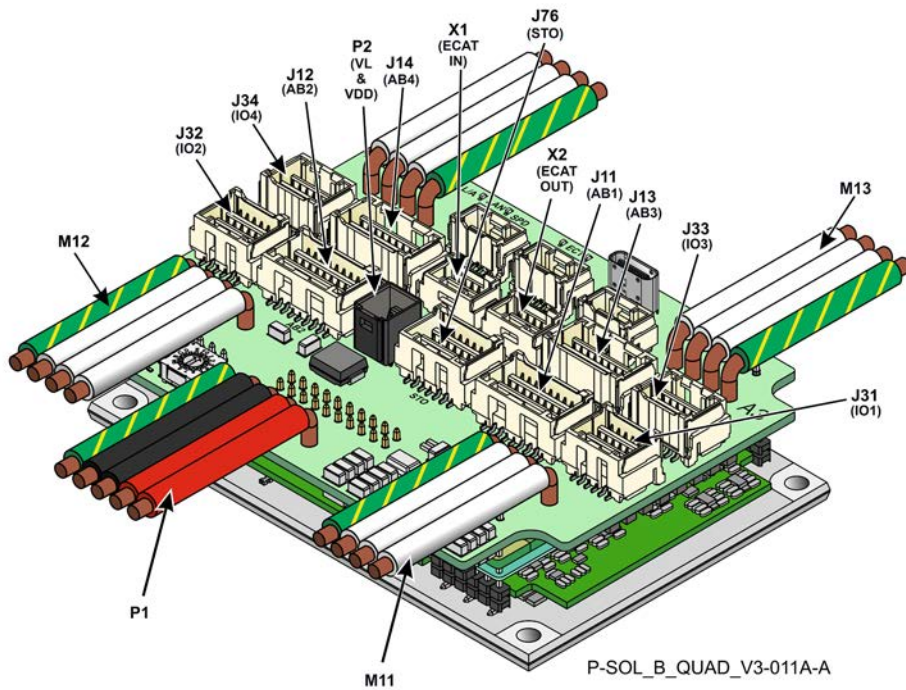


Figure 6: Connector and Connector Locations with wired power connection

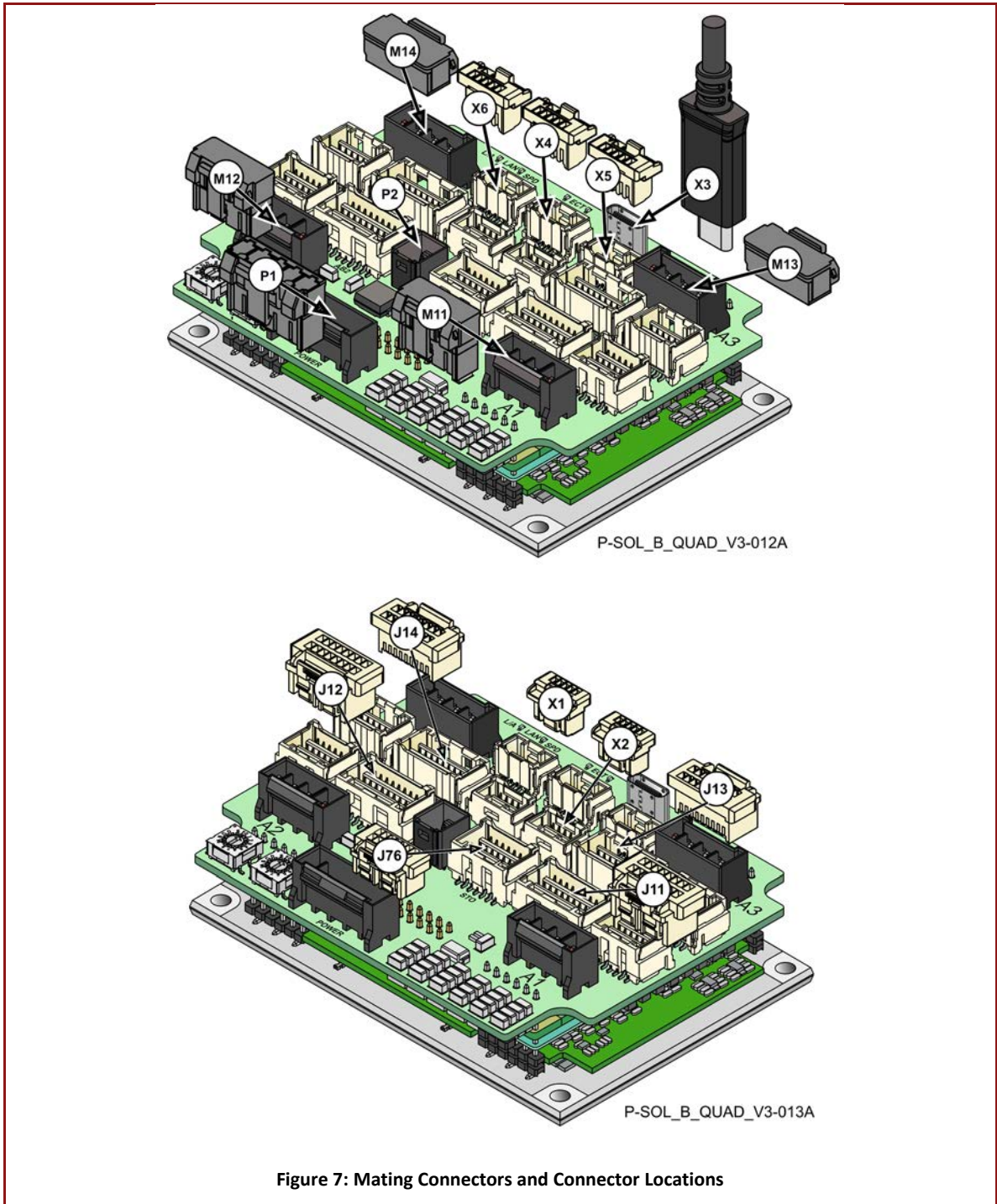


Figure 7: Mating Connectors and Connector Locations

Table 4: Connector Types

The pinouts in Chapter 7: Wiring describe the function of each pin in the Platinum Solo Bee Quad connectors that are listed in Table 4.

6.3 Solo Board Indicator Labelling

The following diagrams describe the board indicator labelling for the Platinum Solo Bee Quad.

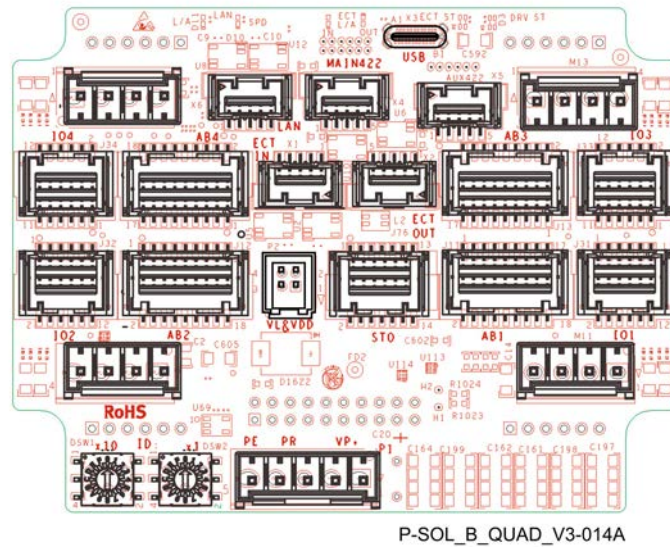


Figure 8: Platinum Solo Bee Quad Board Indicator Labelling

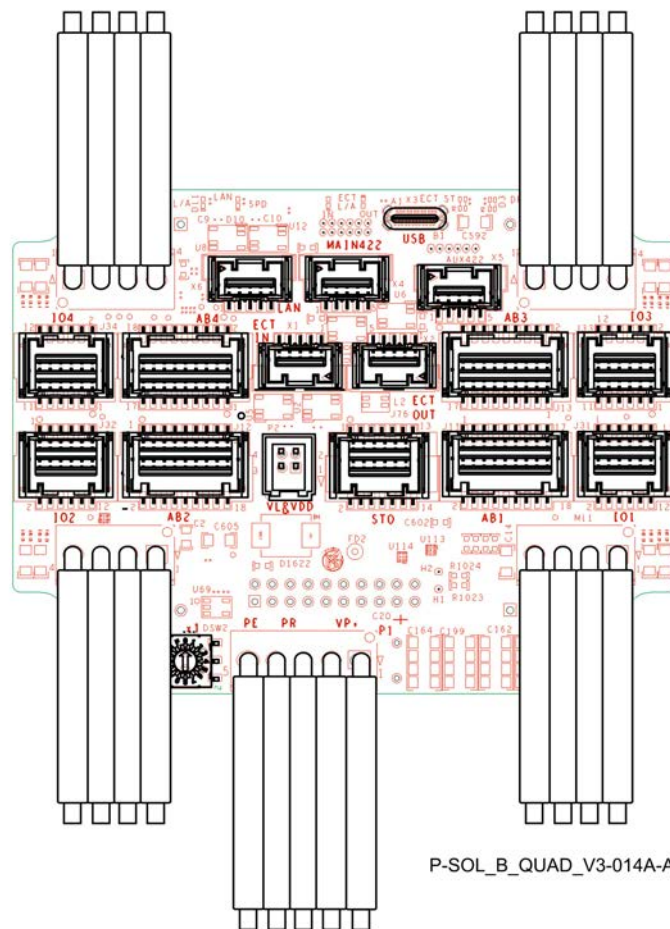


Figure 9: Platinum Solo Bee Quad Board Indicator Labelling (Wired Power Connection)

6.4 Motor Power Connector Pinouts (M11, M12, M13, M14)

The following table describes the pinouts for the Motor Power connectors M11 (Motor M1), M12 (Motor M2), M13 (Motor M3), and M14 (Motor M4).

Pin No.	Pin Signal	Function	Cable – Wires	
			Brushless Motor	Brushed DC Motor
1	M3	Motor phase	Motor	Motor
2	M2	Motor phase	Motor	Motor
3	M1	Motor phase	Motor	No Connection
4	PE	Protective earth, Shield	Motor PE	Motor PE

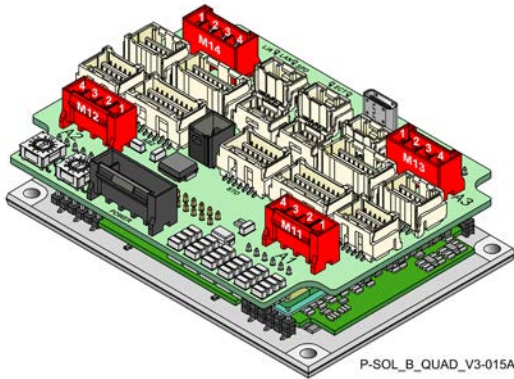
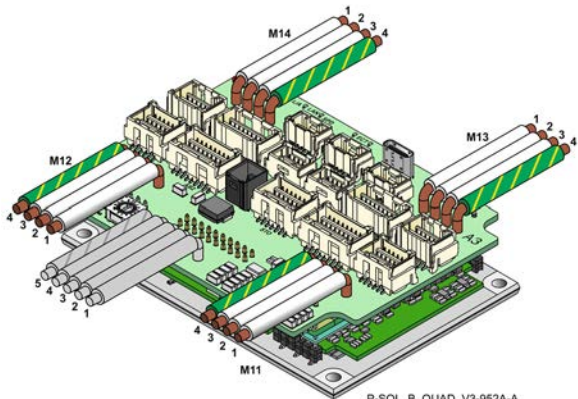
Pin Positions	
 <p>P-SOL_B_QUAD_V3-015A</p>	 <p>P-SOL_B_QUAD_V3-952A-A</p>

Table 5: Main Power and Motor Connections

6.5 Main Power Connector Pinouts (P1)

Pin (P1) No.	Signal	Function	Cable
1	VP+	Positive Power Input	DC Power
2	VP+	Positive Power Input	DC Power
3	PR	Power Return	DC Power
4	PR	Power Return	DC Power
5	PE	Protective Earth	DC Power

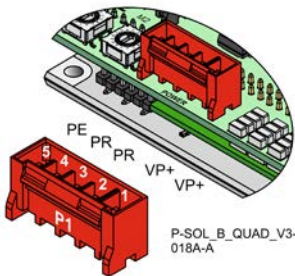
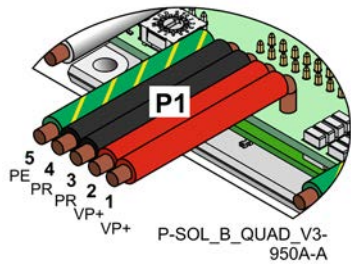
Pin Positions	
 <p>P-SOL_B_QUAD_V3-018A-A</p>	 <p>P-SOL_B_QUAD_V3-950A-A</p>

Table 6: Main Power and Motor Connections

6.6 Control Power Supply Connector Pinouts (P2)

Pin (P2)	Signal	Function
1	VL+	Control Supply Input 14V ÷ 95V, Typical 85V
2	VDD	VDD input (5V to 30V)
3	PR	Control Supply Return
4	VDD_RET	VDD return

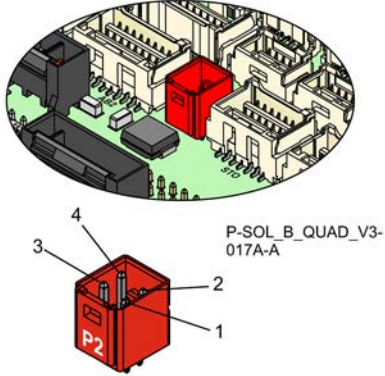

Pin Positions	Cable Connector
 <p>P-SOL_B_QUAD_V3-017A-A</p>	 <p>P-SOL_B_QUAD_V3-026A</p>

Table 7: Control Supply Pins

6.7 STO Connector Pinouts (J76)

Pin (J76)	Signal	Function
1	A1_STO1	A1 Isolated STO1 Input
2	A3_STO1	A3 Isolated STO1 Input
3	A1_STO2	A1 Isolated STO2 Input
4	A3_STO2	A3 Isolated STO2 Input
5	A1_STO_RET	A1 STO Return
6	A3_STO_RET	A3 STO Return
7	A2_STO1	A2 Isolated STO1 Input
8	A4_STO1	A4 Isolated STO1 Input
9	A2_STO2	A2 Isolated STO2 Input
10	A4_STO2	A4 Isolated STO2 Input
11	A2_STO_RET	A2 STO Return
12	A4_STO_RET	A4 STO Return
13	Not Connected	
14	Not Connected	

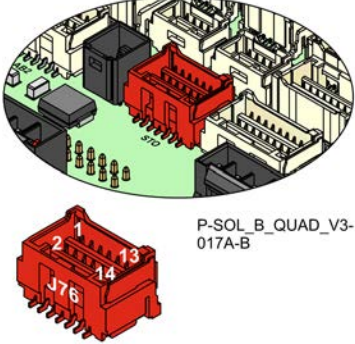
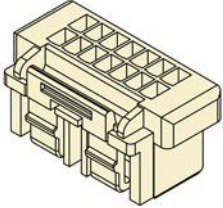
Pin Positions	Cable Connector
 <p>P-SOL_B_QUAD_V3-017A-B</p>	 <p>P-SOL_B_QUAD_V3-086A</p>

Table 8: STO Pins

6.8 Platinum Solo Bee Quad Status Indicator

Figure 10 shows the position of the red/green dual LED, which is used for immediate indication of the Initiation and Working states.

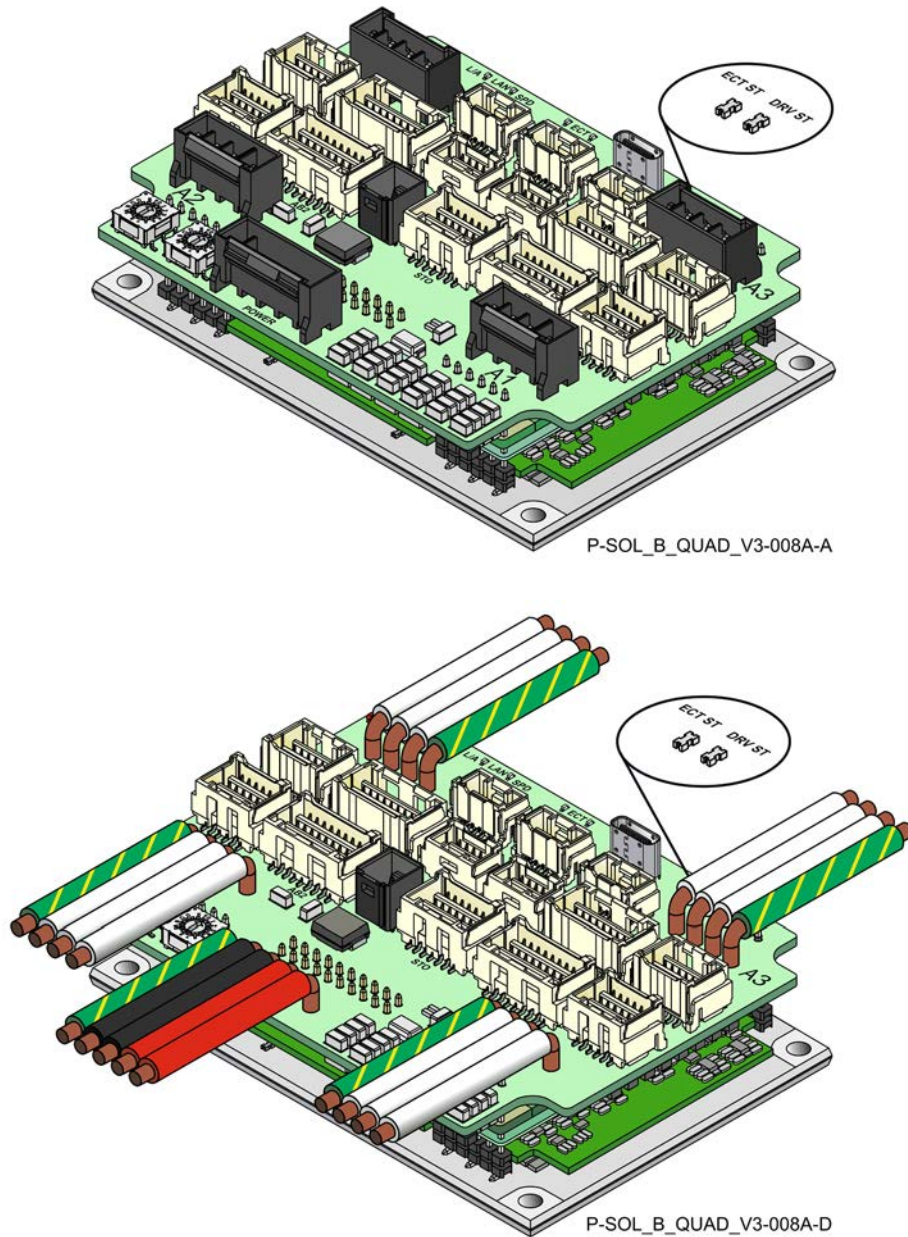


Figure 10: Drive Status Indicator (for horizontal power connectors and wired power)


The red/green dual LED is used for immediate indication of the following states:

- **Initiation state:** In this state the LED indicates whether the drive is in the boot state (blinking red) or in the operational state (steady red).
- **Working state:** In this state the LED indicates whether the drive is in an amplifier failure state (red) or is ready to enable the motor (green).


6.9 Port A and Port B Connector Pinouts (J11, J12, J13, J14)

The following tables describe the pinouts for the Port A and B Feedbacks J11 (AB1), J12 (AB2), J13 (AB3), and J14 (AB4). The Port A and Port B signals are similar for each of the connector pinouts, and are labelled **J1x = J11, J12, J13, or J14, where x=1, 2, 3, 4 axis** in the connection diagrams in section 7.7 Feedbacks (J11, J12, J13, J14) Per Axis.

6.9.1 Port A

Pin Port A		Incremental Encoder	Absolute Serial Encoder								
	Signal	Function	Function								
1	COMRET	Common return (5V Return)									
2	PortA_A+	Channel A +	Absolute encoder clock+ (CLK+_Ax)								
3	5VDC	Encoder +5V supply (5V ±5%, 300mA total per axis)									
		 Note: <table border="1" data-bbox="598 795 1337 952"> <thead> <tr> <th>5VE per axis</th> <th>Current per pin</th> <th>Total Current per axis</th> </tr> </thead> <tbody> <tr> <td>Pin 1</td> <td>200mA</td> <td rowspan="2">300mA</td> </tr> <tr> <td>Pin 2</td> <td>200mA</td> </tr> </tbody> </table>		5VE per axis	Current per pin	Total Current per axis	Pin 1	200mA	300mA	Pin 2	200mA
5VE per axis	Current per pin	Total Current per axis									
Pin 1	200mA	300mA									
Pin 2	200mA										
4	PortA_A-	Channel A -	Absolute encoder clock- (CLK-_Ax)								
5	HA	Hall A Input									
6	PortA_B+	Channel B+	Absolute encoder data+ (DATA+_Ax)								
7	HB	Hall B Input									
8	PortA_B-	Channel B -	Absolute encoder data – (DATA-_Ax))								
9	HC	Hall C Input									

6.9.2 Port B

Pin Port B		Incremental Encoder	Interpolated Analog Encoder								
	Signal	Function	Function								
10	PortB_A+	Channel A+	Sine+_Ax								
11	PortB_INDEX+_Ax	Channel_Index+	Analog_Index+								
12	PortB_A-	Channel A -	Sine-_Ax								
13	PortB_INDEX-_Ax	Channel_Index-	Analog_Index-								
14	PortB_B+	Channel B+	Cosine+_Ax								
15	5VDC	Encoder +5V supply (5V ±5%, 300mA total per axis)									
		 Note: <table border="1" data-bbox="730 1796 1380 1960"> <thead> <tr> <th>5VE per axis</th> <th>Current per pin</th> <th>Total current per axis</th> </tr> </thead> <tbody> <tr> <td>Pin 1</td> <td>200mA</td> <td rowspan="2">300mA</td> </tr> <tr> <td>Pin2</td> <td>200mA</td> </tr> </tbody> </table>		5VE per axis	Current per pin	Total current per axis	Pin 1	200mA	300mA	Pin2	200mA
5VE per axis	Current per pin	Total current per axis									
Pin 1	200mA	300mA									
Pin2	200mA										
16	PortB_B-	Channel B-	Cosine-_Ax								
17	COMRET	Common return (5V Return)									

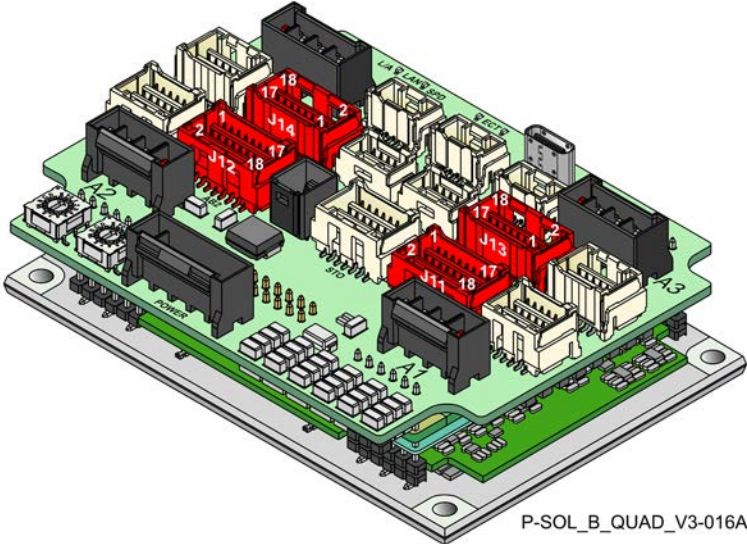
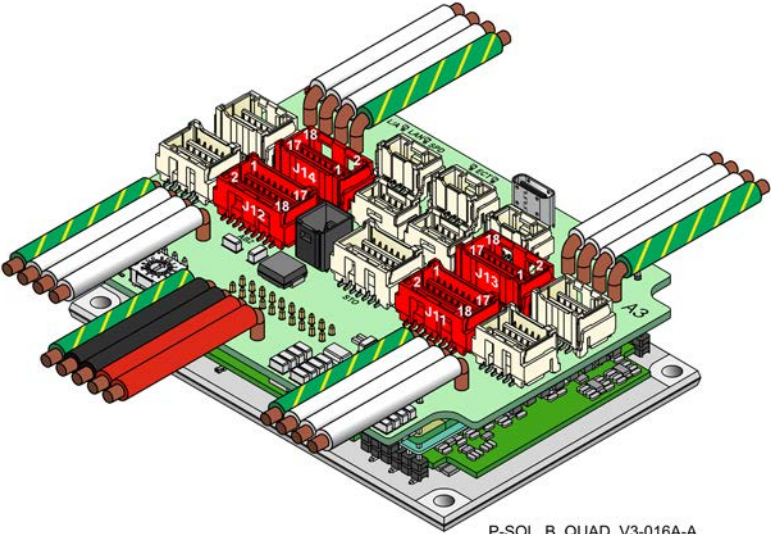
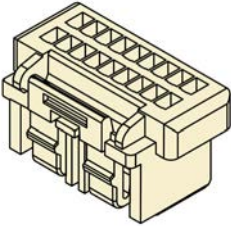
18	COMRET	Common return (5V Return)
Pin Positions		Cable Connector
 <p>P-SOL_B_QUAD_V3-016A</p>  <p>P-SOL_B_QUAD_V3-016A-A</p>		 <p>P-SOL_B_QUAD_V3-088A-A</p>

Table 9: Port A and Port B Pin Assignments

6.10 Digital I/Os, & Analog Inputs Connector Pinouts (J31, J32, J33, J34)

The Digital I/Os and Analog Inputs connector includes the following functions:

- I/O
- Analog input

In the following table x= 1 (IO1, J31), 2 (IO2, J32), 3 (IO3, J33), 4 (IO4, J34) axis.

The Digital I/O and Analog Input signals are similar for each of the connector pinouts, and are labelled **J3x = J31, J32, J33, or J34**, in the connection diagrams in section 7.8 Digital I/Os (J31, J32, J33, J34) Per Axis.

Pin	Signal	Function
1	ANALOG_RET	Analog return
2	VDD_RET	Output Return
3	ANALOG_Ax+	Differential Analog input for connector J3x ±10V
4	VDD_OUT	VDD, OUTPUT only up to 0.75A
5	ANALOG_Ax-	Differential Analog input complement for connector J3x ±10V
6	PCL_TYPE	VDD – Ax Inputs and Outputs PLC Sink VDD_RET – Ax Inputs and Outputs PLC Source Open – Ax Outputs PLC Source
7	IN1_Ax	Input 1 for connector J3x
8	IN2_Ax	Input 2 for connector J3x
9	IN3_Ax	Input 3 for connector J3x
10	IN4_Ax	Input 4 for connector J3x
11	OUT1_Ax	IO Feature PLC Output 1 for connector J3x with two options: Isolated, up to 250mA and OUT2_Ax Isolated, up to 500mA Or Isolated, up to 500mA and OUT2_Ax Isolated, up to 250mA IO Feature 5V Logic Up to 15mA
12	OUT2_Ax	IO Feature PLC Output 2 for connector J3x with two options: Isolated, up to 250mA and OUT1_Ax Isolated, up to 500mA Or Isolated, up to 500mA and OUT1_Ax Isolated, up to 250mA IO Feature 5V Logic Up to 15mA

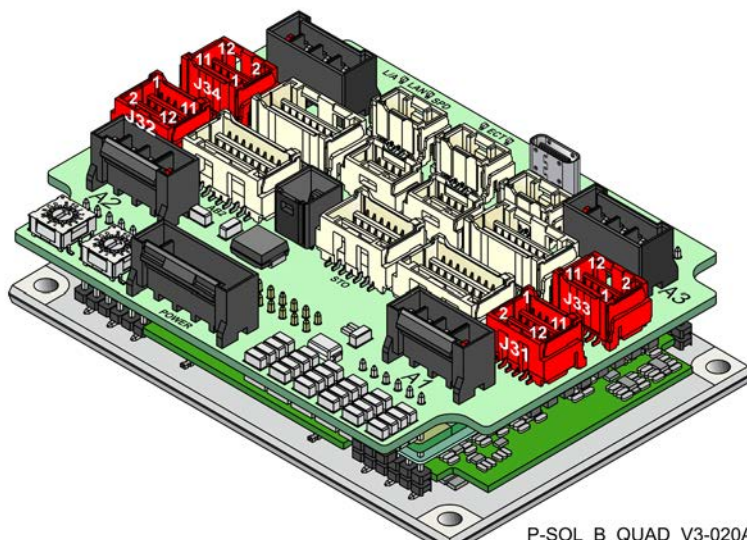
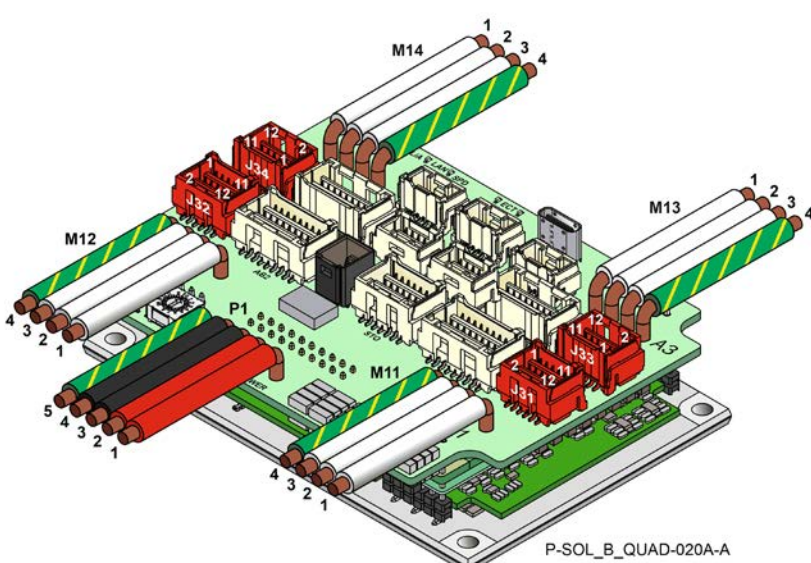
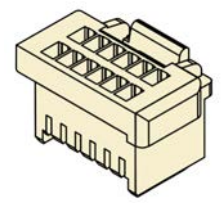
Pin Positions	Cable Connector
 <p>P-SOL_B_QUAD_V3-020A</p>  <p>P-SOL_B_QUAD-020A-A</p>	 <p>P-SOL_B_QUAD_V3-031A</p>

Table 10: Digital I/Os, and Analog Inputs Pin Assignments

6.11 USB 2.0 Connector Pinouts (X3)

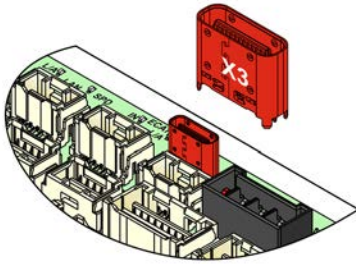

Pin (X3)	Signal	Function
A1	COMRET	Common return
A2	Not Connected	
A3	Not Connected	
A4	USB_VBUS	USB VBUS 5 V
A5	Not Connected	
A6	USBD+	USB _P line
A7	USBD-	USB _N line
A8	Not Connected	
A9	USB_VBUS	USB VBUS 5 V
A10	Not Connected	
A11	Not Connected	
A12	COMRET	Common return
B1	COMRET	Common return
B2	Not Connected	
B3	Not Connected	
B4	USB_VBUS	USB VBUS 5 V
B5	Not Connected	
B6	USBD+	USB _P line
B7	USBD-	USB _N line
B8	Not Connected	
B9	USB_VBUS	USB VBUS 5 V
B10	Not Connected	
B11	Not Connected	
B12	COMRET	Common return
Pin Positions		Cable Connector
 <p>P-SOL_B_QUAD_V3-066A-A</p>		 <p>USB TYPE C CABLE</p> <p>P-SOL_B_QUAD-V3-087A</p>

Table 11: USB Device Mini-B - Pin Assignments

6.12 RS-232/RS-422 Serial Communication Main Connector Pinouts (X4)

Pin (X4)	RS-232		RS-422	
	Signal	Function	Signal	Function
1	RS232_TX	RS232 Level Transmit	RS422_TX+	Differential RS-232 Transmit
2	NC		RS422_TX-	Differential RS-232 Transmit Complement
3	RS232_RX	RS232 Level Receive	RS422_RX+	Differential RS-232 Receive
4	NC		RS422_RX-	Differential RS-232 Receive Complement
5	COMRET	Common Return	COMRET	Common Return

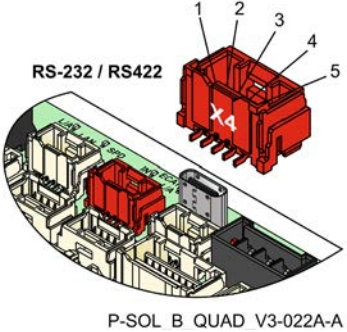
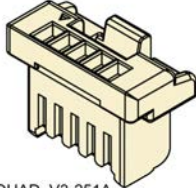
Pin Positions	Cable Connector
 <p>RS-232 / RS422</p> <p>P-SOL_B_QUAD_V3-022A-A</p>	 <p>P-SOL_B_QUAD_V3-251A</p> <p>CLIK-MATE HOUSING FE 5PIN(1x5) P=1.5MM</p>

Table 12: RS-232/RS-422 Main Pin Assignments

6.13 RS-422 Serial Communication Auxiliary Connector Pinouts (X5)

The X5 connector is designed for RS-422 serial communication.

Pin (X5)	RS-422	
	Signal	Function
1	RS422_TX+	Differential RS-232 Transmit
2	RS422_TX-	Differential RS-232 Transmit Complement
3	RS422_RX+	Differential RS-232 Receive
4	RS422_RX-	Differential RS-232 Receive Complement
5	COMRET	Common Return

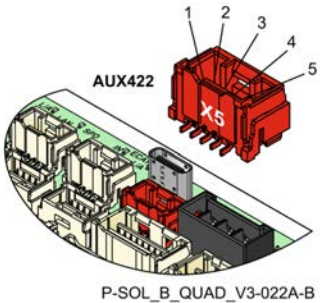
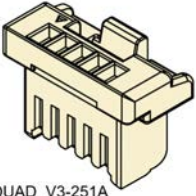
Pin Positions	Cable Connector
 <p>AUX422</p> <p>P-SOL_B_QUAD_V3-022A-B</p>	 <p>P-SOL_B_QUAD_V3-251A</p> <p>CLIK-MATE HOUSING FE 5PIN(1x5) P=1.5MM</p>

Table 13: RS-422 Auxiliary Pin Assignments

6.14 EtherCAT IN Connector Pinouts (X1)

Fieldbus communications are industrial network protocols for real-time distributed control that allows connection of servo drives. The Platinum Solo Bee Quad supports the EtherCAT fieldbus type industrial network protocol.

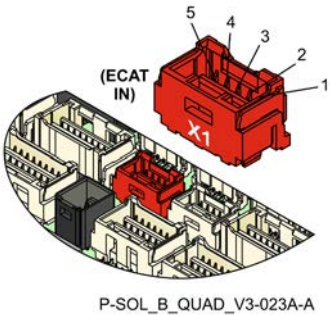
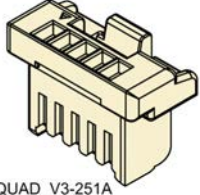
Pin (X1)	Signal	Function
1	EtherCAT_IN_TX+	EtherCAT in
2	EtherCAT_IN_TX-	EtherCAT in
3	EtherCAT_IN_RX+	EtherCAT in
4	EtherCAT_IN_RX-	EtherCAT in
5	PE	Shield drain wire
Pin Positions		Cable Connector
 <p>P-SOL_B_QUAD_V3-023A-A</p>		 <p>P-SOL_B_QUAD_V3-251A CLIK-MATE HOUSING FE 5PIN(1x5) P=1.5MM</p>

Table 14: EtherCAT IN / Ethernet Pin Assignments

6.15 EtherCAT OUT/Ethernet Connector Pinouts (X2)

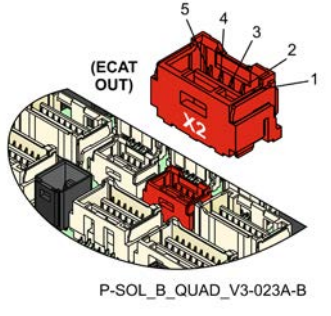
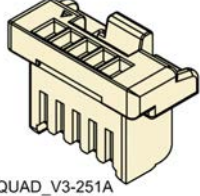
Pin (X2)	Signal	Function
1	EtherCAT_OUT_TX+	EtherCAT out transmit +
2	EtherCAT_OUT_TX-	EtherCAT out transmit -
3	EtherCAT_OUT_RX+	EtherCAT out receive +
4	EtherCAT_OUT_RX-	EtherCAT out receive -
5	PE	Shield drain wire
Pin Positions		Cable Connector
 <p>P-SOL_B_QUAD_V3-023A-B</p>		 <p>P-SOL_B_QUAD_V3-251A CLIK-MATE HOUSING FE 5PIN(1x5) P=1.5MM</p>

Table 15: EtherCAT OUT Pin Assignments

6.16 LAN Connector Pinouts (X6)

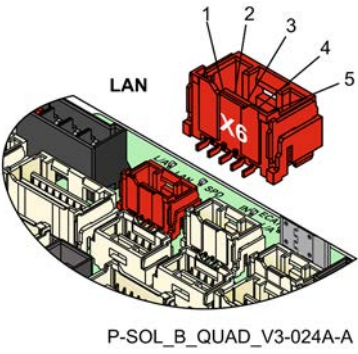
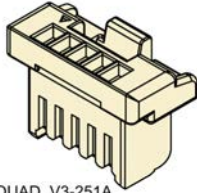
Pin (X6)	Signal	Function
1	LAN_TX+	Ethernet transmit +
2	LAN_TX-	Ethernet transmit -
3	LAN_RX+	Ethernet receive +
4	LAN_RX-	Ethernet receive -
5	PE	Shield drain wire
Pin Positions		Cable Connector
 <p>P-SOL_B_QUAD_V3-024A-A</p>		 <p>P-SOL_B_QUAD_V3-251A CLIK-MATE HOUSING FE 5PIN(1x5) P=1.5MM</p>


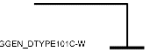
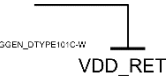
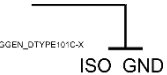
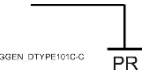

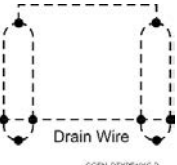
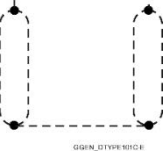

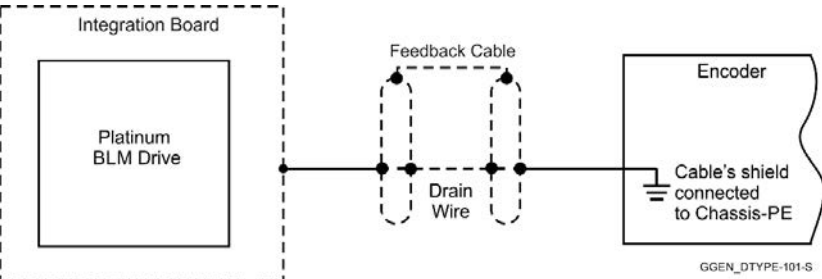
Table 16: LAN Pin Assignments

Chapter 7: Wiring

7.1 Wiring Legend

Once the product is mounted, you are ready to wire the device. Proper wiring, grounding and shielding are essential for ensuring safe, immune and optimal servo performance of the drive.

The following table legend describes the wiring symbols detailed in all installation guides.

Wiring Symbol	Description
	Earth connection (PE)
 GGEN_DTYPE101C-W	User Side: This symbol signifies that any type of grounding may be used on the user side
 GGEN_DTYPE101C-W VDD_RET	VDD Return
 GGEN_DTYPE101C-X ISO_GND	Isolated Ground
 GGEN_DTYPE101C-C PR	Power Return
 GGEN_DTYPE101C-S	COMRET Common at the Drive
 GGEN_DTYPE101C-G Drain Wire	Shielded cable with drain wire. The drain wire is a non-insulated wire that is in direct contact with the braid (shielding). Shielded cable with drain wire significantly simplifies the wiring and earthing.
 GGEN_DTYPE101C-E	Shielded cable braid only, without drain wire.
 GGEN_DTYPE101C-F	Twisted-pair wires
 GGEN_DTYPE-101-S Encoder Earthing. The cable's shield is connected to the chassis (PE) in the connector. The servo drive shield is connected to Earth.	

7.2 The Platinum Solo Bee Quad Connection Diagrams

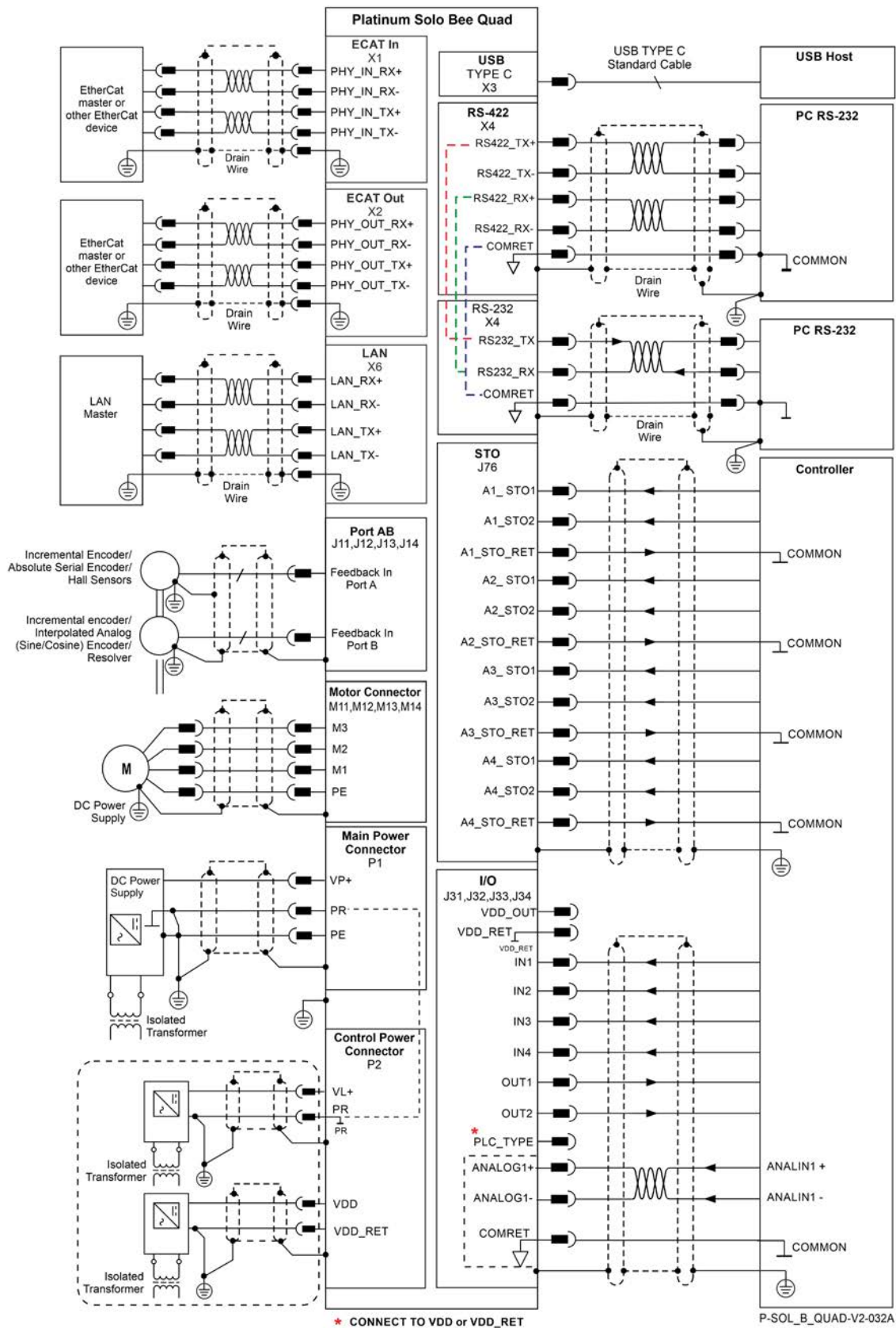


Figure 11: Platinum Solo Bee Quad EtherCAT Connection Diagram

7.3 Wiring the Female CON CLIK-MATE Connectors

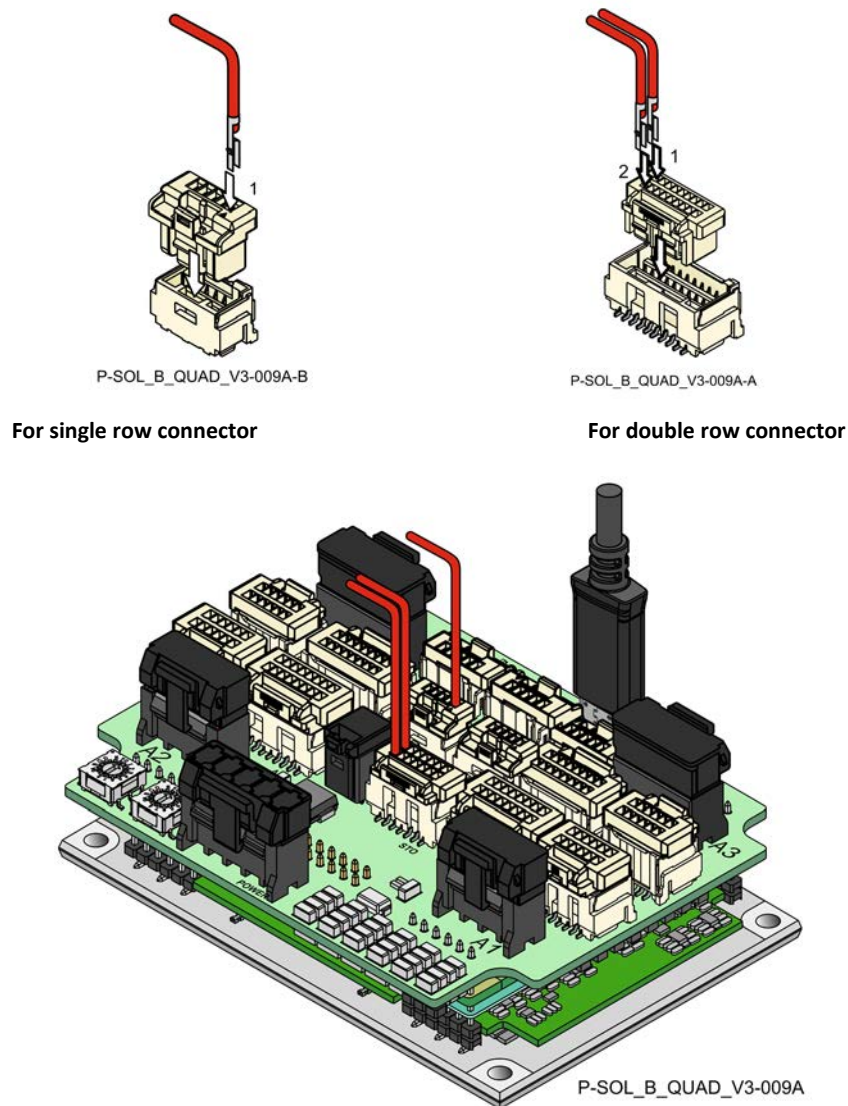


Figure 12: Inserting a wire/pin to the Female CON CLIK-MATE Connector

To insert a wire/pin to the female CON CLIK-MATE connectors do the following:

1. Select the relevantly colored wire to insert to a specific rectangular compartment on the female connector.
2. Use the appropriate Molex crimping plier (Molex P/N 63819-4600) to fasten a pin connector to the end of the wire.
3. Place the connector on a flat surface, in the orientation as shown in Figure 12. Notice that the rectangular slot has a niche at the bottom of the slot.
4. Insert the wire connector to the slot as shown in Figure 12. Make sure that the connector protrusion is inserted to the bottom of the rectangular slot.
When inserting the wire connector to a slot in the second row, make sure to orientate the wire pin in the direction shown in Figure 12.
5. Repeat the same procedure for all other wire connections.

7.4 Motor Power (M11, M12, M13, M14) Per Axis

When connecting the Platinum Solo Bee Quad to several similar motors, all should be wired in an identical manner. This will enable the same settings to run on all drives.

For Motor connections to 4 axes (Figure 13) and 6 axes (Figure 14), use the following connection diagrams and procedure per axis, depending on the motor type.

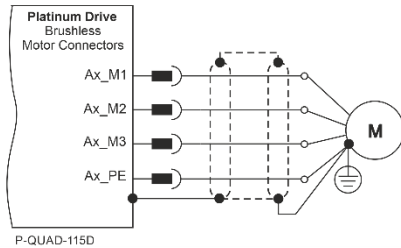
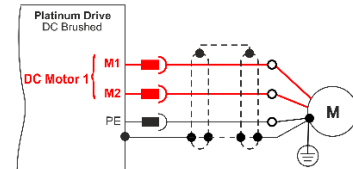


Figure 13: 4-Axis Brushless Motor Power Connection Diagram

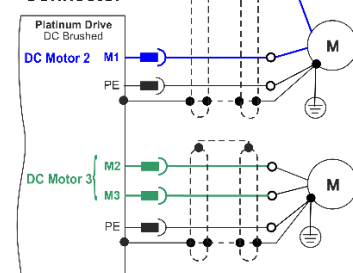
To connect the motor power per axis:

1. Ensure that the motor chassis is properly earthed.
2. Connect the appropriate wire from the Motor Power cables to the M1, M2, M3, and PE terminals on the Platinum Solo Bee Quad.
Make sure not to bundle the wires.
3. The phase connection is arbitrary as Elmo Application Studio (EAS II) will establish the proper commutation automatically during setup. When tuning a number of drives, you can copy the setup file to the other drives and thus avoid tuning each drive separately. In this case the motor-phase order must be the same as on the first drive.
4. For high EMI environment, it is highly recommended to use a 5-wire shielded (not twisted) cable for the motor connection. The gauge is determined by the actual RMS current consumption of the motor.
5. Connect the cable shield to the closest ground connection at the motor end.
For better EMI performance, the shield should be connected to Earth Connection (heat sink mounting holes).

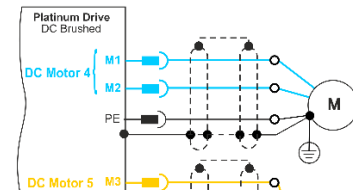
AXIS 1 Phase Connector



AXIS 2 Phase Connector



AXIS 3 Phase Connector



AXIS 4 Phase Connector

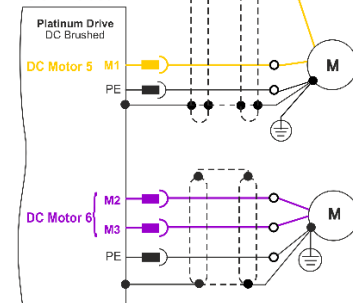


Figure 14: 6-Axis Brushed Motor Power Connections Diagram

7.5 Main (P1) and Control Power (P2)

The Platinum Solo Bee Quad receives power from Main and Control supplies and delivers power to the motor.

7.5.1 Main Supply

There are two possible power ratings for the Platinum Solo Bee Quad:

- 100V is for the 10 to 95 VDC
- 200V is for the 20 to 195 VDC

For power rating 200V

Two DC power sources are required, a DC power source of 20 to 195 VDC isolated from the Mains, and a control supply 14 to 95 VDC (isolated from the Mains) for the logic.

For power rating of 100V

Only a single DC Power source of 10 to 95 VDC isolated from the Mains, is required for the main power and also for the control power. However, a control power supply can be added for the logic.



Note: Both the 10 to 95 VDC and 20 to 195 VDC power sources must be isolated from the Mains.

Connect the DC power source cable to the VP+ and PR terminals on the main power connector.

To connect the main power:

1. The DC power supply source must be isolated from the Mains.
2. For best immunity, it is highly recommended to use twisted and shielded cables for the DC power source. A 3-wire shielded cable should be used. The gauge is determined by the actual current consumption of the motor.
3. Connect the cable shield to the closest earth connection near the power supply.
4. Connect the PE to the closest earth connection near the power supply.
5. Connect the PR to the closest earth connection near the power supply.
6. Before applying power, first verify the polarity of the connection.

7.5.2 Control Supply

For power rating 200V

The Control supply 14V to 95V is required.

For power rating 100V

The Control supply 14V to 95V can be added for the 100V power rating.



Note: The source of the Control Supply must be isolated from the Mains.

Connect the VL+ and PR terminal to the control Connector.

To connect your integration board to the control supply:

1. The source of the control supply must be isolated from the Mains.
2. For safety reasons, connect the return (common) of the control supply source to the closest earth connection near the control supply source.
3. Connect the cable shield to the closest earth connection near the control supply source.
4. Before applying power, verify the polarity of the connection.

7.5.3 Power Supply for 200V Power Rating

For Power Rating 200V, two DC power sources are required; a main power 20 to 195 VDC power source isolated from the Mains, and a control supply 14V to 95V (isolated from the Mains) for the logic. The following figure describes the connection of main power and control.

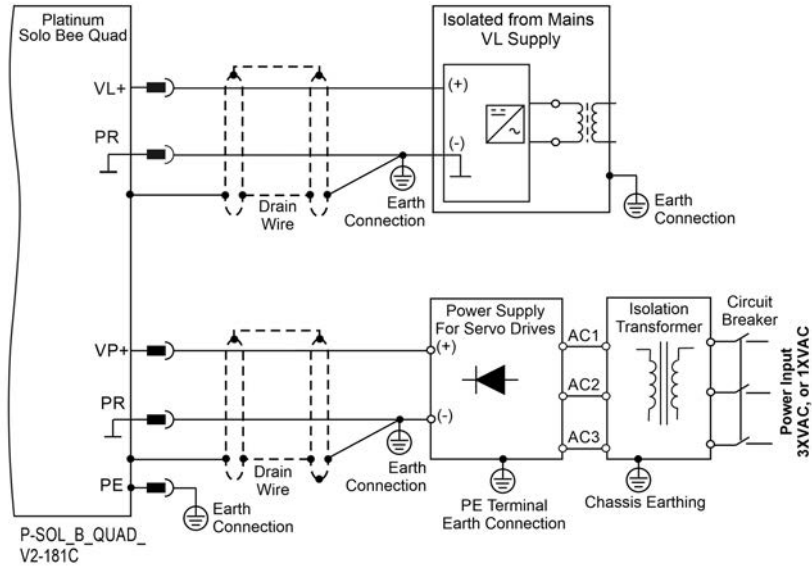


Figure 15: Power Supply Connection Diagram for Power Rating 200V



Note: Make sure to connect the PR to the closest earth connection near the power supply.

7.5.4 Power Supply for 100V Power Rating



Important Note Regarding the INPUT CAPACITANCE:

For Platinum Solo Bee Quad modules <math><15A</math>, a DC Bus Capacitance of $\sim 2300\mu F$ is recommended to be connected between the VP+ and the PR, as close as possible (10 – 20 cm) to the Platinum Solo Bee Quad, as shown in the following figure.

For Platinum Solo Bee Quad modules $\geq 15A$, a DC Bus Capacitance of $\sim 2300\mu F$ or more must be connected between the VP+ and the PR, as close as possible (10 – 20 cm) to the Platinum Solo Bee Quad, as shown in the following figure.

The Elmo TAB-100 (a DC Bus connection and capacitance bank of $\sim 2300\mu F$) is recommended. Please refer to the TAB-100 Installation Guide. Alternatively, an equal or larger capacitor can be used.

7.5.4.1 Single Power Supply

For power rating 100V, a single Power Supply is required which contains a “smart” control-supply algorithm, enabling the Platinum Solo Bee Quad to operate with only one power supply with no need for a Control power supply for the logic.

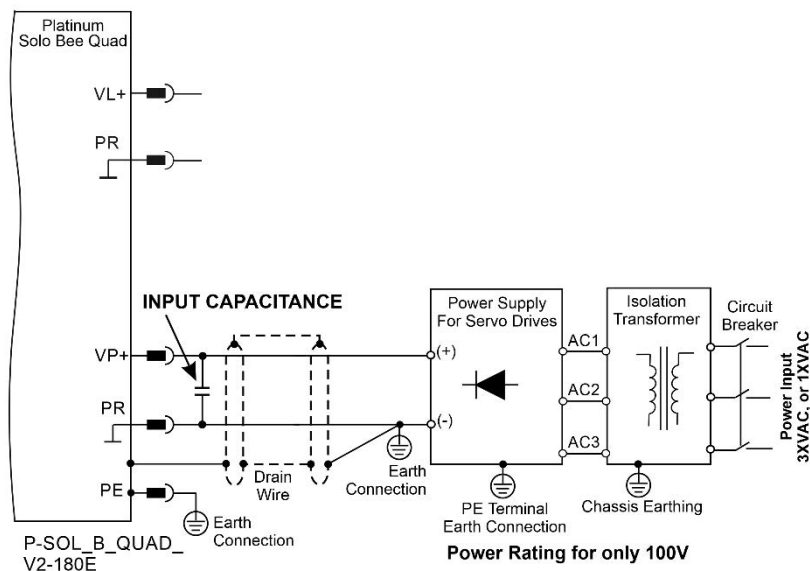


Figure 16: Main Power Supply Connection Diagram (No Control Supply)



Note: Make sure to connect the PR to the closest earth connection near the power supply.

7.5.4.2 Shared Supply

A single DC Power Supply can supply the power for logic as well as the main power. If separation between the main DC power source and a control supply is required, then a control supply (isolated from the Mains) can be connected by implementing "diode coupling" (Figure 17).

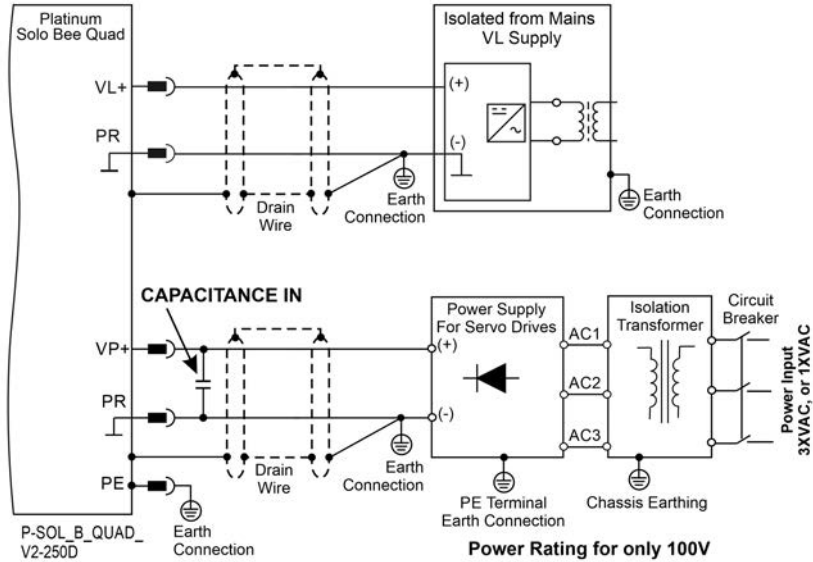


Figure 17: Shared Optional Power Supply Connection Diagram



Note: Make sure to connect the PR to the closest earth connection near the power supply.

7.6 STO (Safe Torque Off) (J76) Per Axis

7.6.1 Source Mode – PLC Voltage Level

Refer to the diagrams below for the PLC Source option connection.

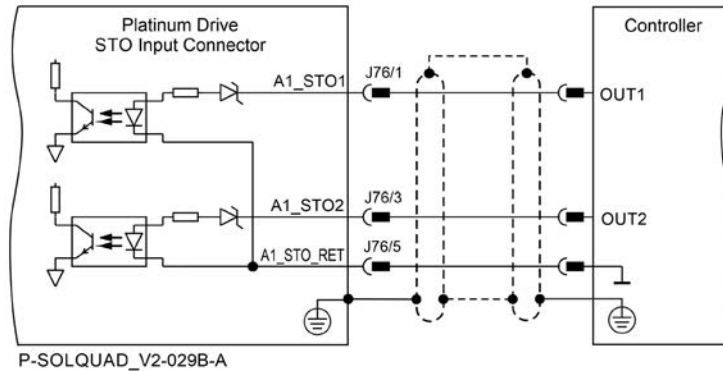


Figure 18: STO Shrouded Type Input Connection – PLC Source Option for Axis A1

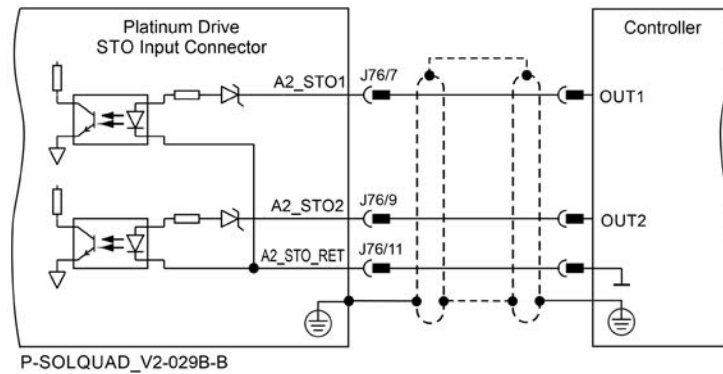


Figure 19: STO Shrouded Type Input Connection – PLC Source Option for Axis A2

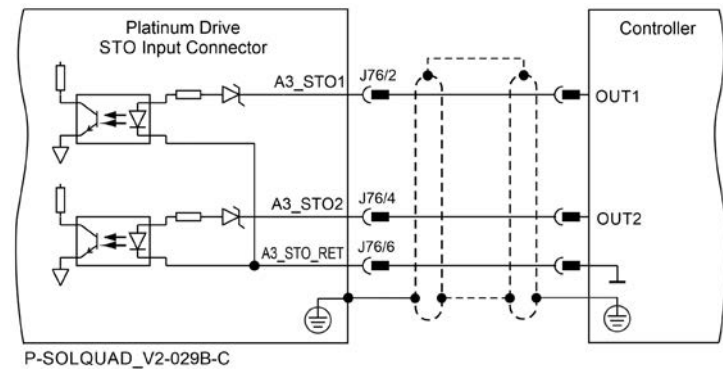


Figure 20: STO Shrouded Type Input Connection – PLC Source Option for Axis A3

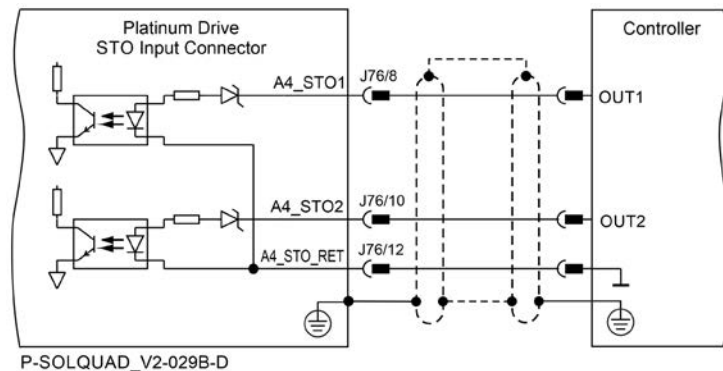


Figure 21: STO Shrouded Type Input Connection – PLC Source Option for Axis A4

7.6.2 TTL Mode – TTL Voltage Level

Refer to the diagrams below for TTL option connection.

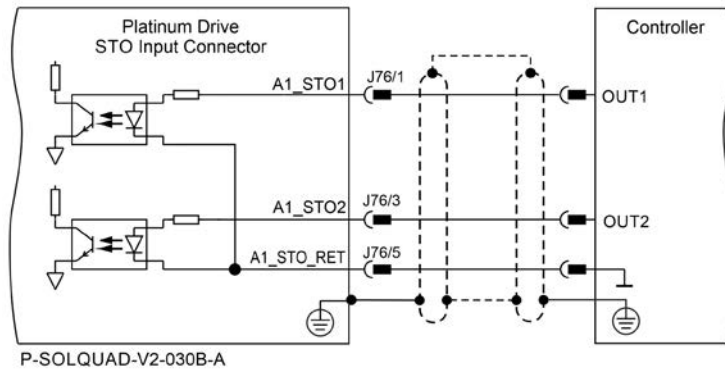


Figure 22: STO Input Connection – TTL Option for Axis 1

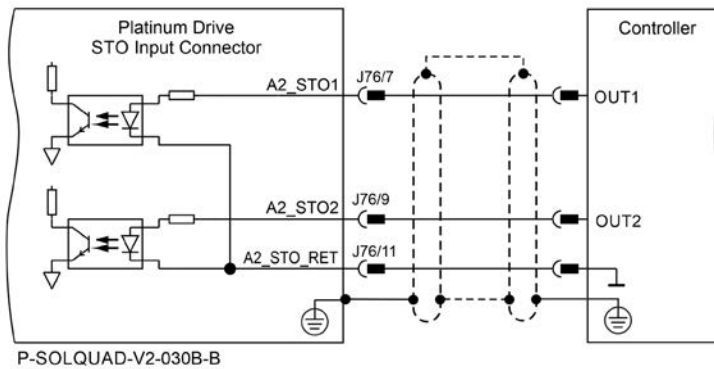


Figure 23: STO Input Connection – TTL Option for Axis 2

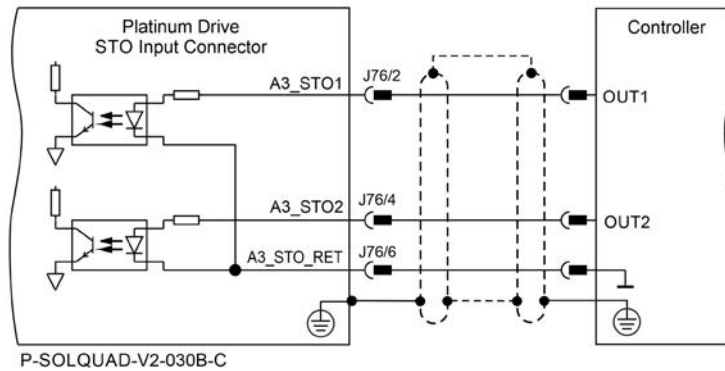


Figure 24: STO Input Connection – TTL Option for Axis 3

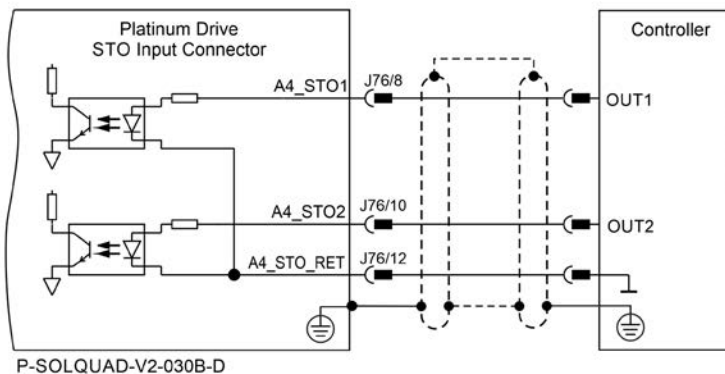


Figure 25: STO Input Connection – TTL Option for Axis 4

7.7 Feedbacks (J11, J12, J13, J14) Per Axis

For J1x = J11, J12, J13, or J14, where x=1, 2, 3, 4 axis, the following connection diagrams describe the Port A and Port B feedback connections per axis.



Note:

When using two encoder supply pins, only 200mA is allowed for each pin.

7.7.1 Feedback Port A

Port A supports the following sensor inputs:

- Incremental Encoder or absolute serial Encoder
- Differential pulse-width modulation (PWM) signal input
- Differential Pulse & Direction signal inputs

7.7.1.1 Incremental Encoder

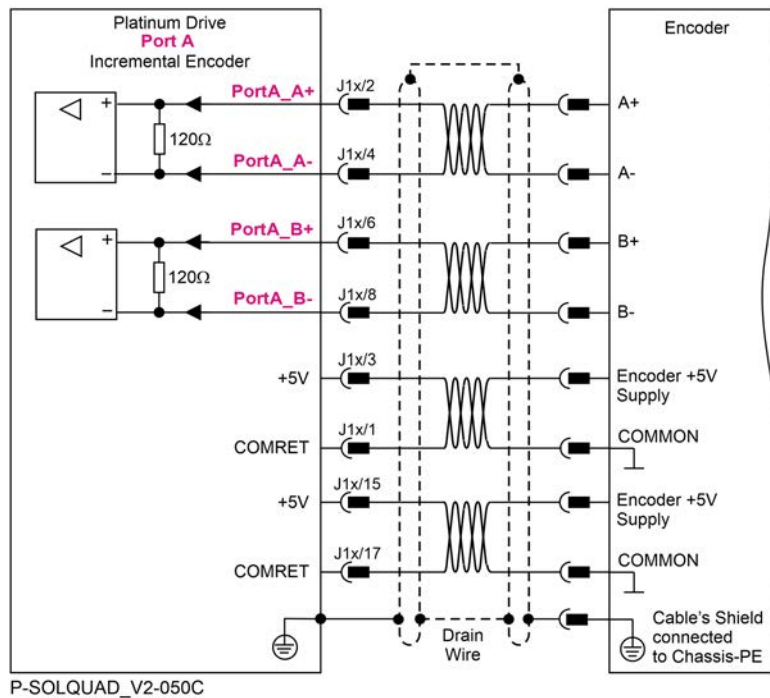


Figure 26: Port A Incremental Encoder Input – Recommended Connection Diagram

7.7.1.2 Absolute Serial Encoder

The following Absolute Encoder types are supported:

- EnDat 2.2
- Biss C and Biss B
- SSI
- Hiperface

The following is the diagram connection of the EnDat, Biss, SSI:

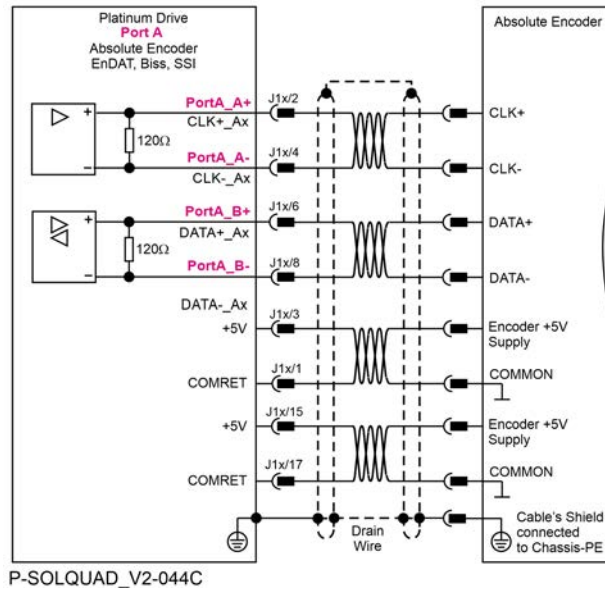


Figure 27: Absolute Serial Encoder – Recommended Connection Diagram for EnDat, Biss, SSI

7.7.1.3 Hiperface

The following figure describes the connection diagram.

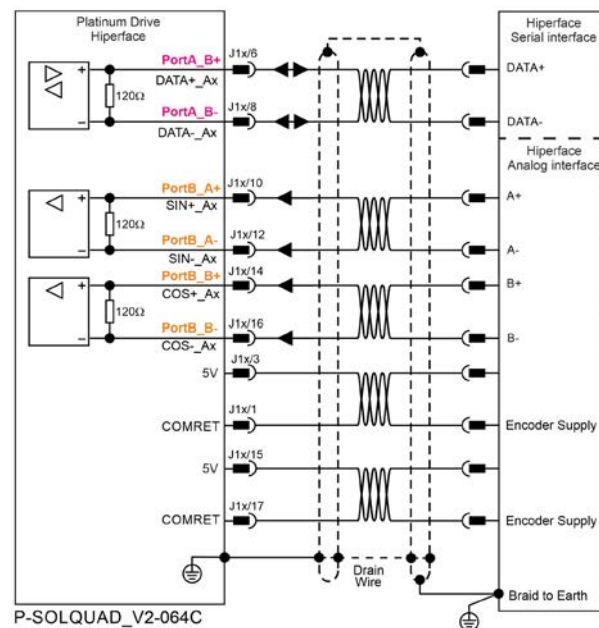


Figure 28: Absolute Serial Encoder – Recommended Connection Diagram for Stegmann Hiperface

7.7.2 Feedback Port B

Port B supports any of the following sensors:

- Incremental Encoder
- Interpolated analog Encoder
- Analog Hall sensors

Differential PWM signal input can be connected to port B

7.7.2.1 Incremental Encoder

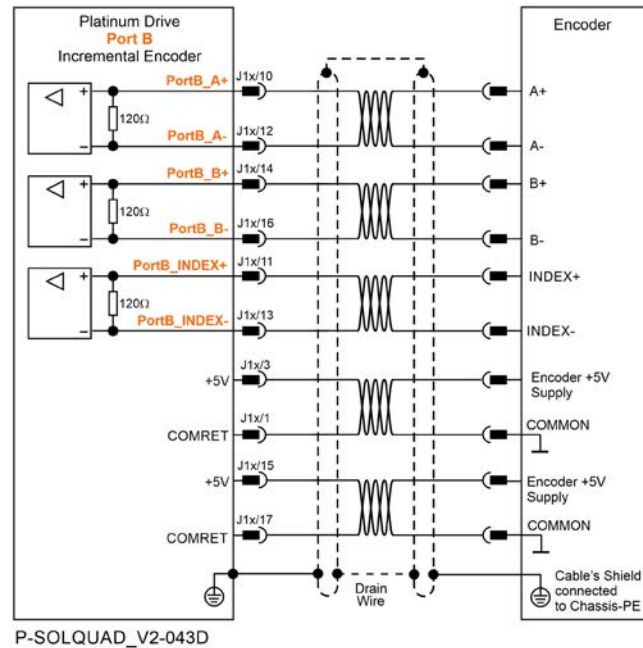


Figure 29: Port B Incremental Encoder Input – Recommended Connection Diagram

7.7.2.2 Interpolated Analog (Sine/Cosine) Encoder

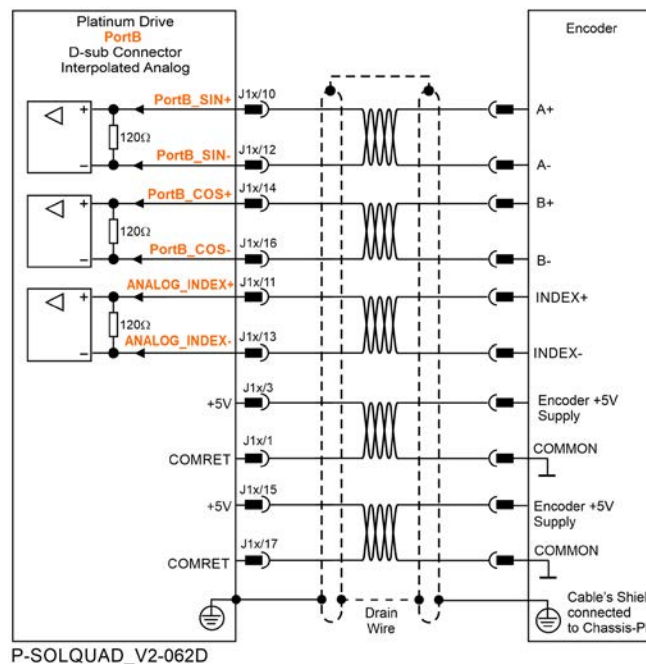


Figure 30: Port B - Interpolated Analog Encoder Connection Diagram

7.7.3 Feedback - Hall Sensors

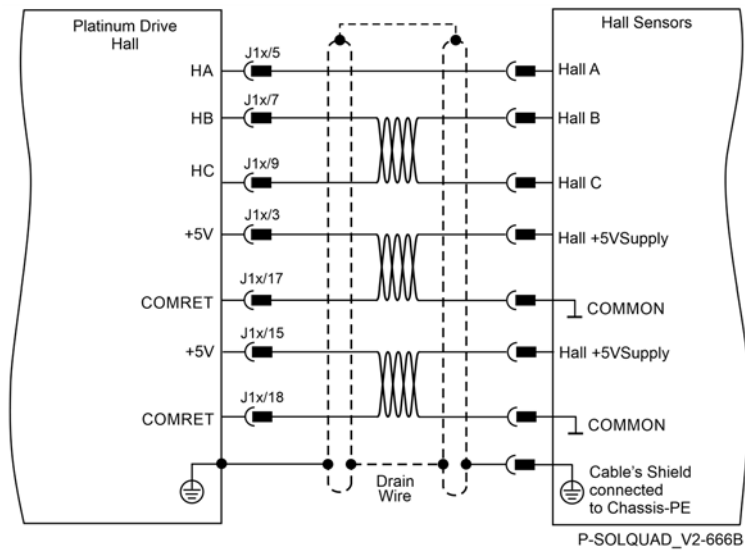


Figure 31: Hall Sensors Connection Diagram

7.8 Digital I/Os (J31, J32, J33, J34) Per Axis

For J3x = J31, J32, J33, or J34, where x=1, 2, 3, 4 axis, the following connection diagrams describe the Digital IO connections per axis.

7.8.1 Digital IO PLC Source and Sink Mode (IO Type: V)

7.8.1.1 Digital Input and Output PLC Source Mode

The following figure describes the connections at the I/O Port for the Digital Input and Output PLC Source Mode.

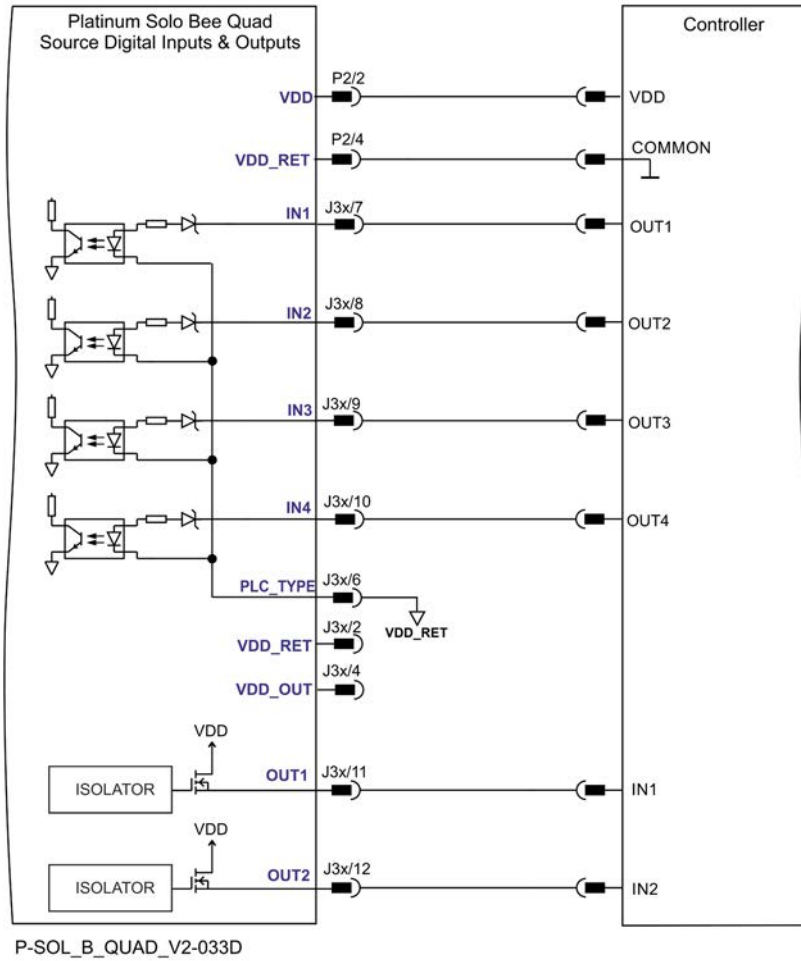
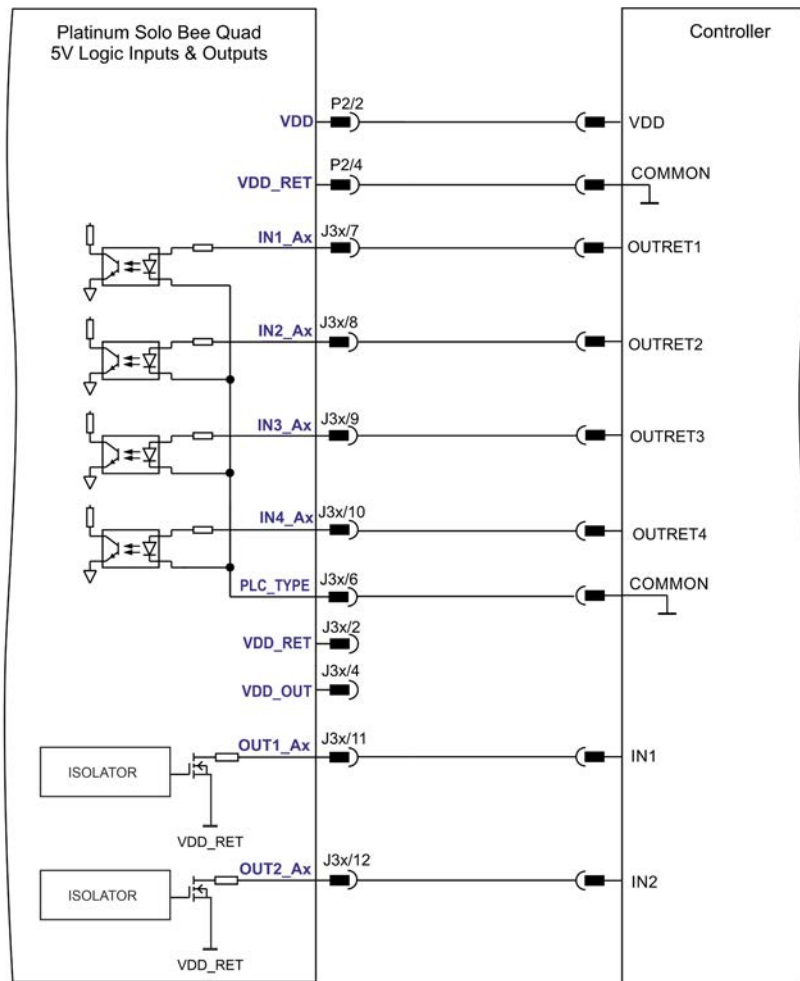


Figure 32: Digital Input and Output Connection Diagram – Source PLC Option

7.8.1.2 Digital Input and Output PLC Sink Mode

The following figures describes the connections at the I/O Port for the Digital Input and Output PLC Sink Mode.



P-SOL_B_QUAD_V2-334C

Figure 33: Digital Input and Output Connection Diagram – PLC Sink Option

7.8.2 Digital IO 5V Logic (IO Type: U)

The following figures describes the connections at the I/O Port for the Digital Input and Output 5V Logic Mode.

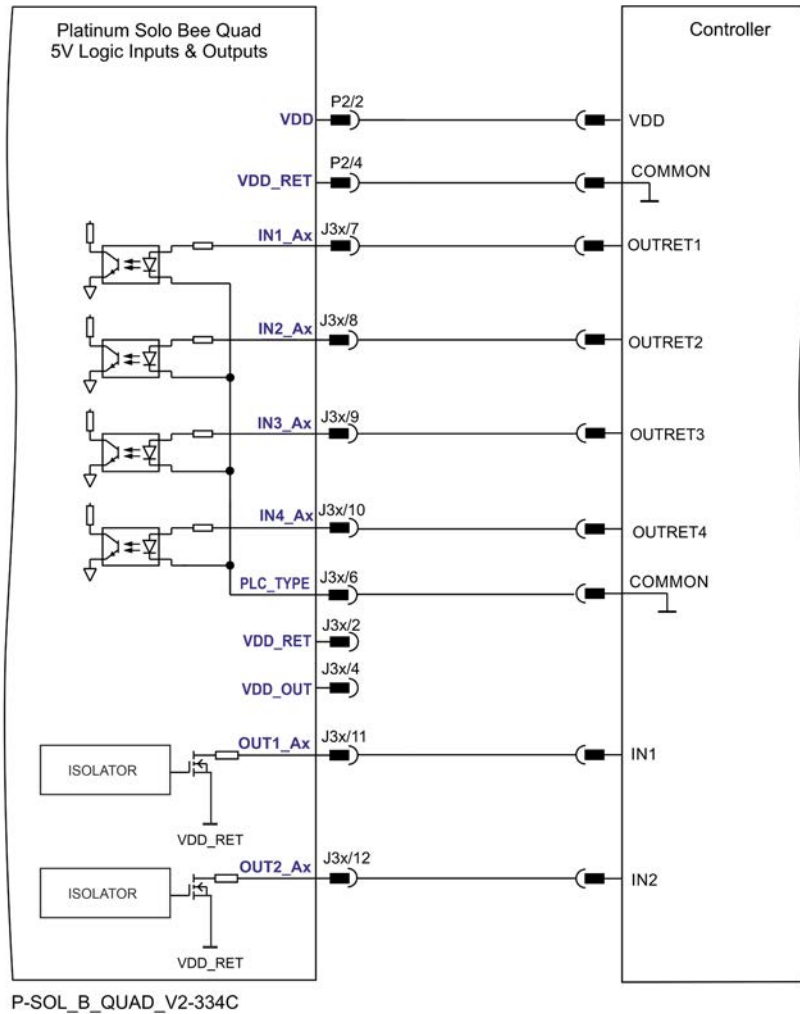


Figure 34: Regular Digital Input and Output 5V Logic Mode Connection Diagram

7.9 Analog Input -Differential (J31, J32, J33, J34) Per Axis

For J3x = J31, J32, J33, or J34, where x=1, 2, 3, 4 axis, the following connection diagram describes the Analog Input connections per axis.

The following circuit describes the internal interface of the Analog input.

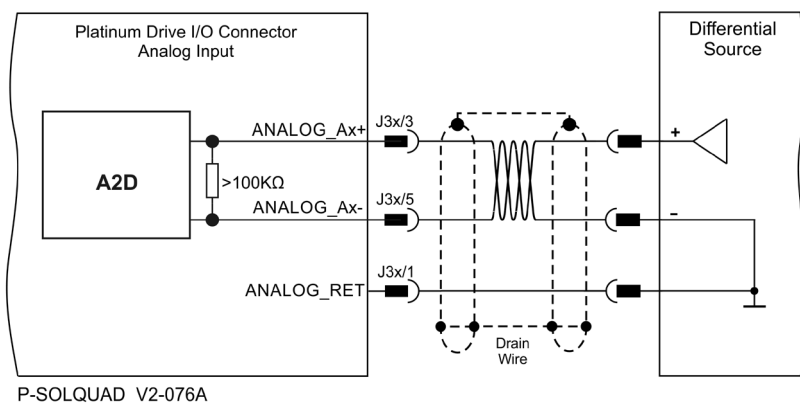


Figure 35: Differential Analog Input

7.10 Communication

7.10.1 USB 2.0 (X3)

Use a standard USB 2.0 Type C cable and connector to connect the USB.

7.10.2 RS-422 (X4 and X5)/RS-232 (X4) Serial Communication

The X4 Main connector is optionally for either RS-422 or RS-232 communication. However, the X5 Auxiliary connector is designed for only RS-422 (Differential RS-232) communication.

7.10.2.1 RS-422 (Differential RS-232) Serial Communication for both X4 and X5 Connectors

The following describes the RS-422 specification for both X4 Main and X5 Auxiliary connectors.

Specification	Details
Physical layer	Differential RS-232 Full duplex, serial communication
Interface	RS-422
Termination	120 Ohm It is required to connect termination of 120 ohm in the end of the TX signals (refer to the figure below)
Speed	Baud Rate of 0.0048 to 3.60 Mbps
Protocols	For setup and control

The following is recommended when connecting the Differential RS-232 communication cable:

Connect the shield to the ground of the Controller.

Usually, this connection is soldered internally inside the connector at the PC end. You can use the drain wire to facilitate connection.

The following are RS-422 signals:

Signal	Function
RS-422_TX+	Differential RS-232 Transmit
RS-422_TX-	Differential RS-232 Transmit Complement
RS-422_RX+	Differential RS-232 Receive
RS-422_RX-	Differential RS-232 Receive Complement
COMRET	Common Return

7.10.2.2 X4 RS-422 (Differential RS-232) Serial Communication

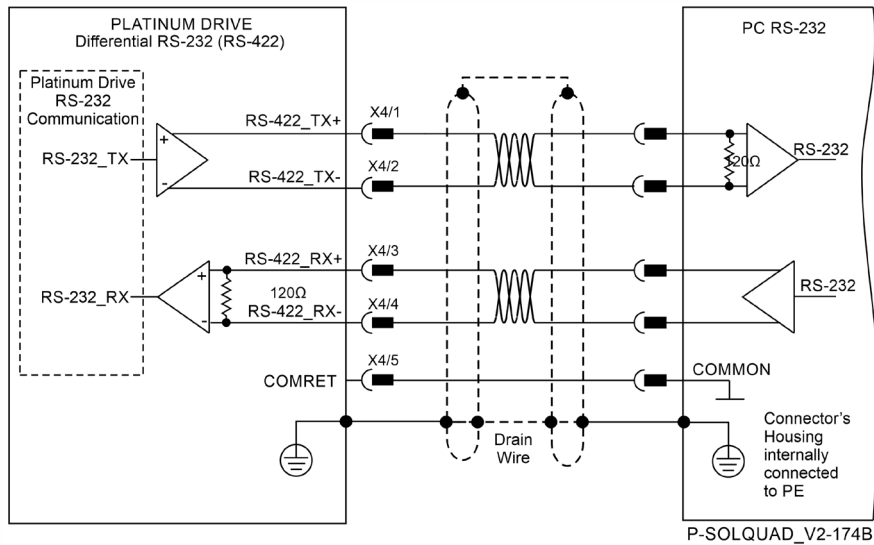


Figure 36: Differential RS-232 Communication Example for Connector X4

7.10.2.3 X4 Main RS-232 Serial Communication

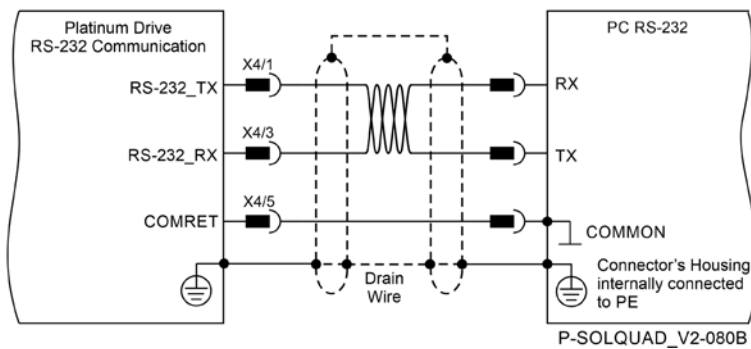


Figure 37: RS-232 Connection Diagram

7.10.2.4 X5 RS-422 (Differential RS-232) Serial Communication

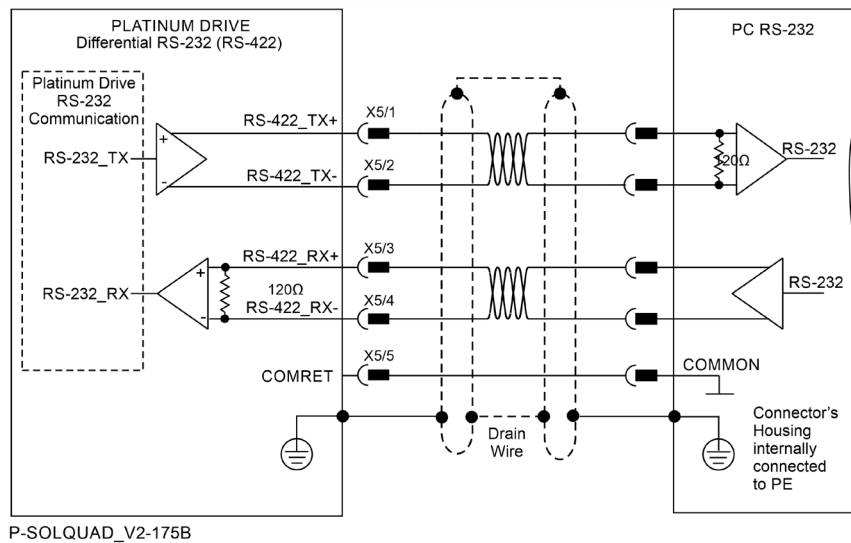


Figure 38: Differential RS-232 Communication Example for Connector X5

7.10.3 EtherCAT (X1 and X2)

7.10.3.1 EtherCAT Connection

The Platinum Solo Bee Quad can serve as an EtherCAT slave device. For this purpose it has two Ports X1 and X2, which are designated as EtherCAT In and EtherCAT Out.

The following drawing describes the EtherCAT communication, and the pinout drawing of the connector.

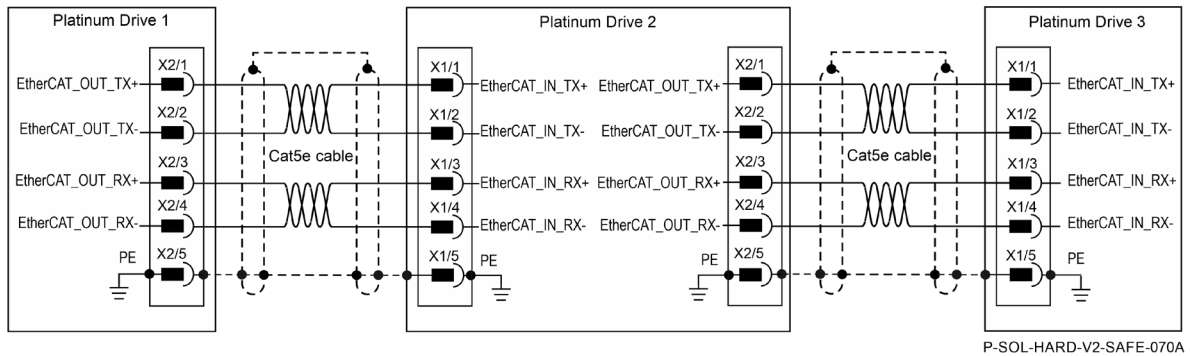


Figure 39: EtherCAT Schematic Diagram for Platinum to Platinum drive connections

7.10.3.2 EtherCAT Status Indicator

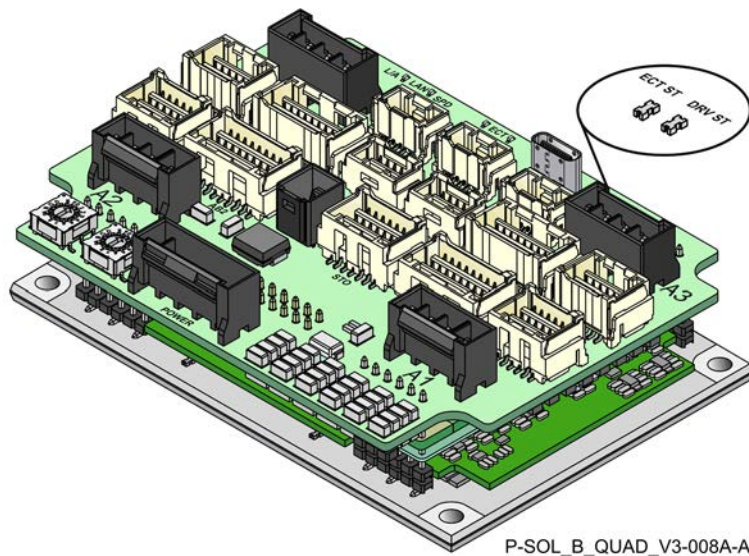


Figure 40: EtherCAT Status LED

The EtherCAT Ports have a status LED. The EtherCAT status indicator is a single red/green dual bi-colored LED that combines the green RUN indicator and the red ERROR indicator of the EtherCAT state machine. For further details, see the EtherCAT Application Manual.

7.10.3.3 EtherCAT Link Indicators

Each of the EtherCAT Ports also has an EtherCAT Link In and EtherCAT Link Out LED, which are shown in Figure 41.

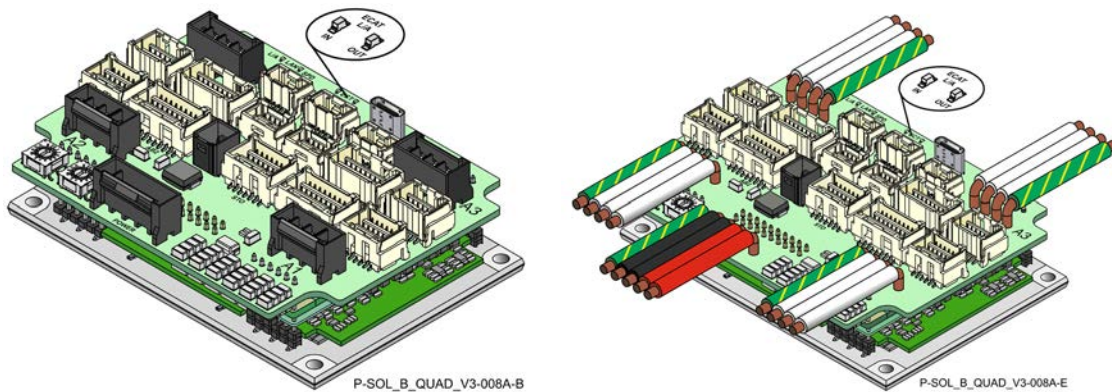


Figure 41: EtherCAT Link LEDs

The green LEDs are the link/activity indicators. They show the state of the applicable physical link and the activity on that link; blinking green, both for the Link Act IN, and Link Act OUT.

LED	State	Meaning
Link /Activity	Off	No link is established
	On	A link is established
	Blinking	There is data transmission activity

7.10.3.4 EtherCAT Address Switches

The Platinum Solo Bee Quad has two rotary switches that allow the user to define a unique node ID to the slave. EtherCAT address switches set the ECAT address (LOW is ADD low, HIGH is ADD high). The two rotary switches offer up to 255 addresses, with the 0 setting referring to No alias address.

Figure 42 displays the switches available in the EtherCAT Version. Refer to the section 7.10.3.4 EtherCAT Address Switches in the [MAN-P-Quartet Hardware Manual](#) for full details.

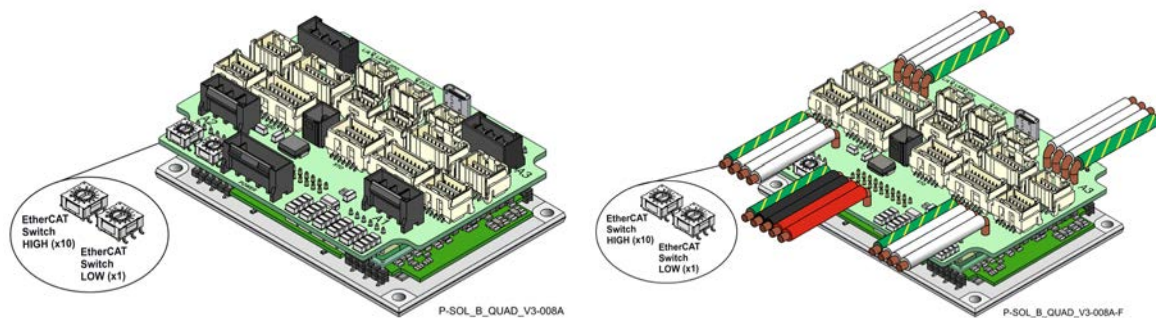


Figure 42: EtherCAT Address Switches

The positions of the switches on the drive are shown in Figure 42. Use a screwdriver to set the low and high bytes values of the drive EtherCAT address. This address is only retrieved after power-up.

7.10.4 LAN Connector Pinouts (X6)

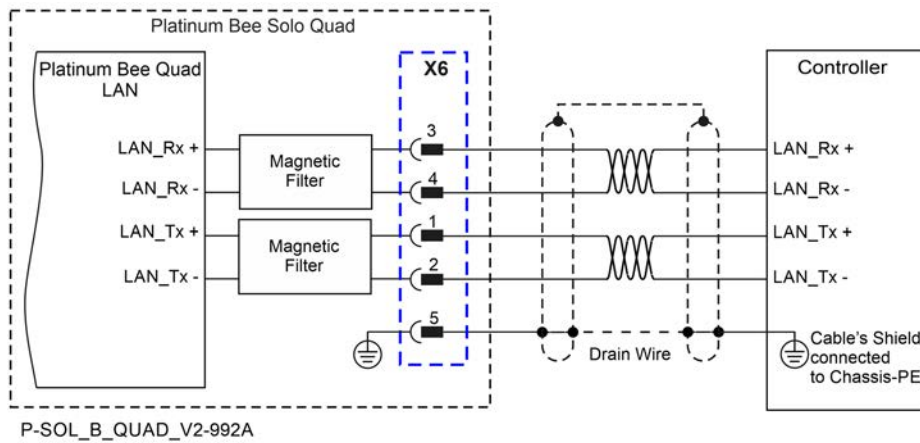


Figure 43: EtherCAT Connection Schematic Diagram

7.10.4.1 LAN Activity Indicator

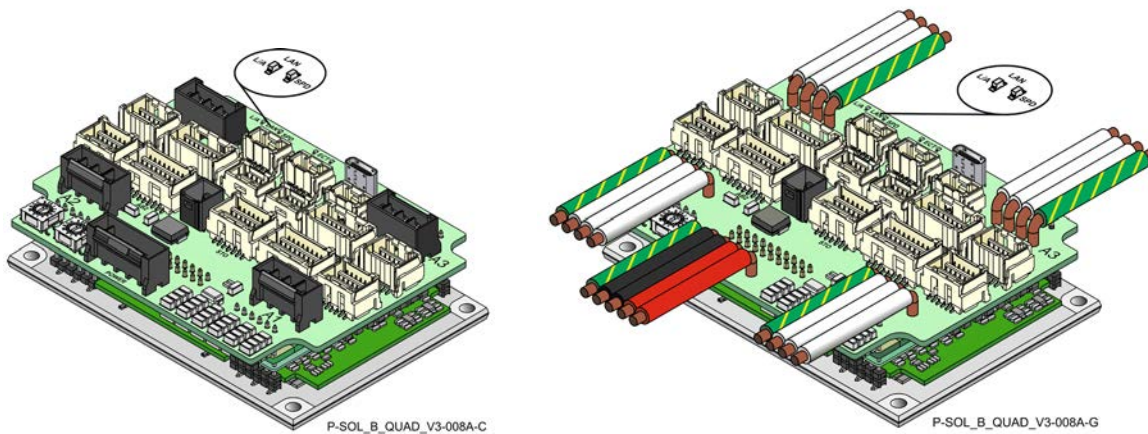


Figure 44: LAN Activity LED

The green LED is the link/activity indicator (Figure 44). It shows the state of the applicable physical link and the activity on that link.

The orange LED is the speed indicator (Figure 44). It shows the speed of the connection on the Ethernet line. The possible states of these LEDs are summarized in Table 17.

LED	State		Definition
Link /Activity	Off	No connection	Green color, defines the state of the physical link/activity.
	On	Connection established (Link)	
	Blinking	Data transmission activity (Act)	
Speed	On	100 Mbps Connection (default) Speed	Orange color, defines the speed of the LAN line.
	Off	10 Mbps Connection Speed	

Table 17: LED States

Chapter 8: Powering Up

After the Platinum Solo Bee Quad is connected to its device, it is ready to be powered up.



Caution:

Before applying power, ensure that the DC supply is within the specified range and that the proper plus-minus connections are in order.

8.1 Initializing the System

After the Platinum Solo Bee Quad has been connected and mounted, the system must be set up and initialized. This is accomplished using the *EASII*, Elmo’s Windows-based software application. Install the application and then perform setup and initialization according to the directions in the *EASII User Manual*.

8.2 Heat Dissipation

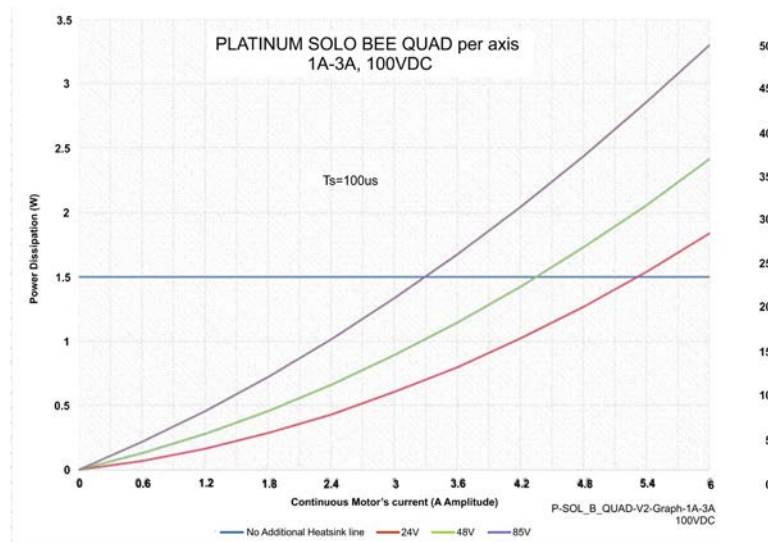
The best way to dissipate heat from the Platinum Solo Bee Quad is to mount it so that its heat sink faces up. For best results leave approximately 10 mm of space between the Platinum Solo Bee Quad’s heat sink and any other assembly.

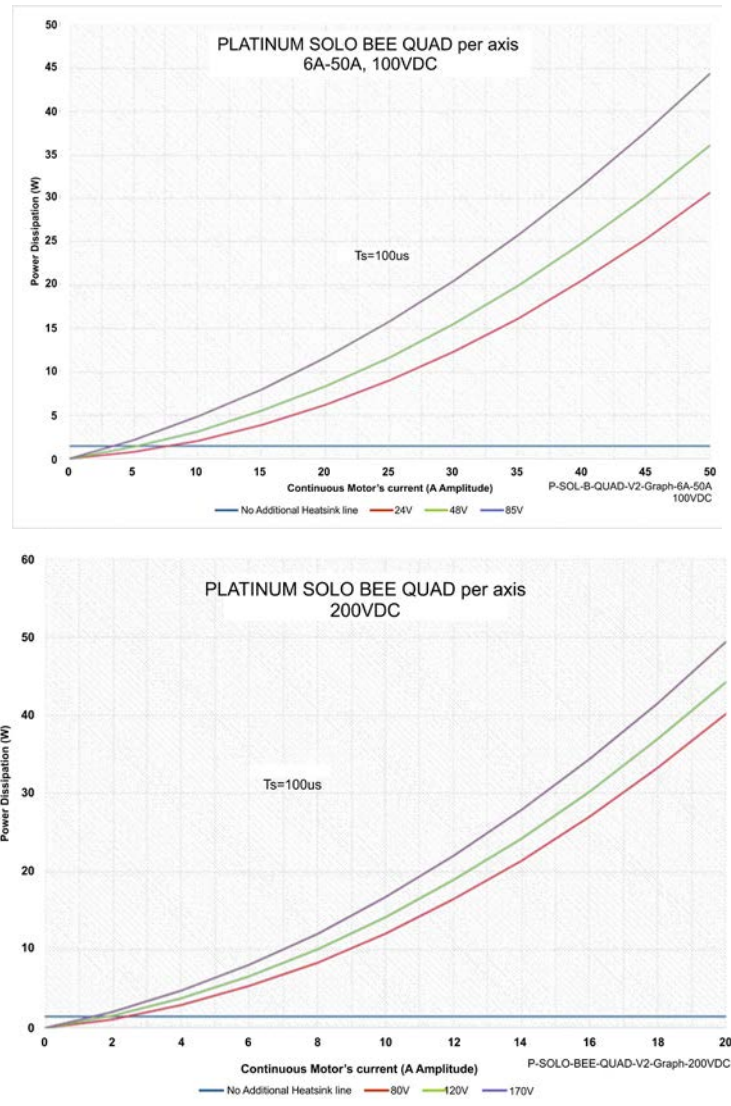
8.2.1 Thermal Data

- Heat dissipation capability (θ): Approximately 10 °C/W
- Thermal time constant: Approximately 240 seconds (thermal time constant means that the Platinum Solo Quad will reach 2/3 of its final temperature after 4 minutes)
- Shut-off temperature: 86 °C to 88 °C (measured on the heat sink)

8.2.2 Heat Dissipation Data Per Axis

Heat dissipation is shown in graphically below:





8.2.3 How to Use the Charts

The charts above are based upon theoretical worst-case conditions. Actual test results show 30% to 50% better power dissipation.

To determine if your application needs a heat sink:

1. Allow maximum heat sink temperature to be 80 °C or less.
2. Determine the ambient operating temperature of the Solo Whistle.
3. Calculate the allowable temperature increase as follows:
For an ambient temperature of 40 °C , $\Delta T = 80^{\circ}\text{C} - 40^{\circ}\text{C} = 40^{\circ}\text{C}$
4. Use the chart to find the actual dissipation power of the drive. Follow the voltage curve to the desired output current and then find the dissipated power.
5. If the dissipated power is below 4 W the Solo Whistle will need no additional cooling.



Note:

The chart above shows that no heat sink is needed when the heat sink temperature is 80 °C, ambient temperature is 40 °C and heat dissipated is 4 Watts.

Chapter 9: Dimensions

This chapter provides detailed technical dimensions regarding the Platinum Solo Bee Quad.

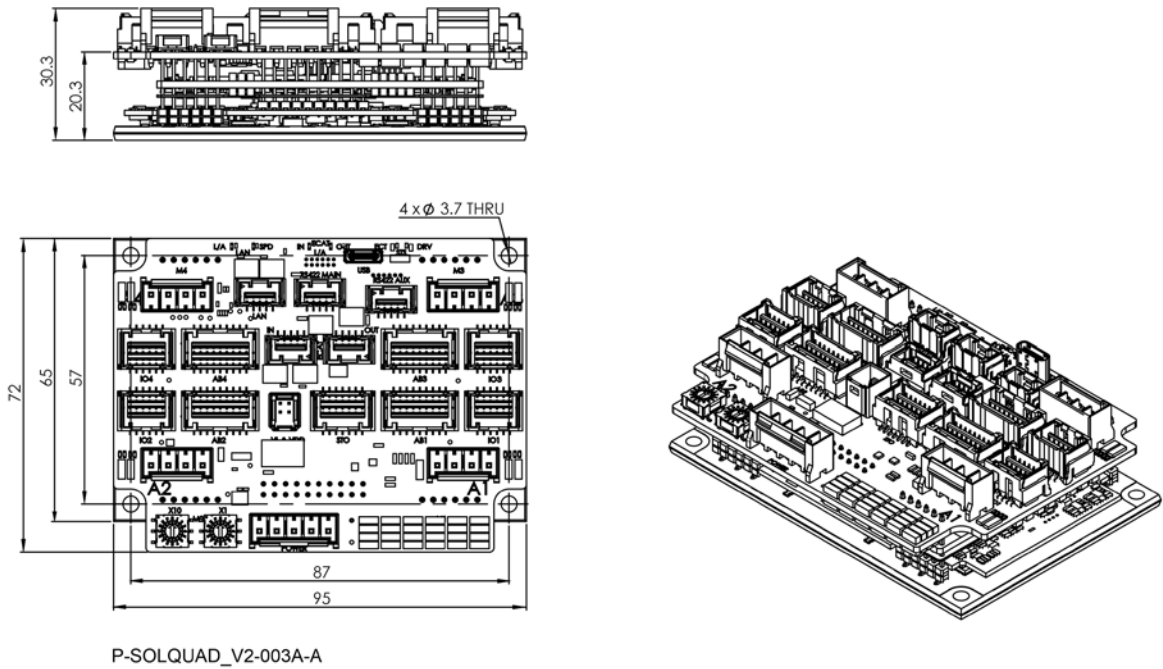


Figure 45: Platinum Solo Bee Quad with Power and Motor Connectors

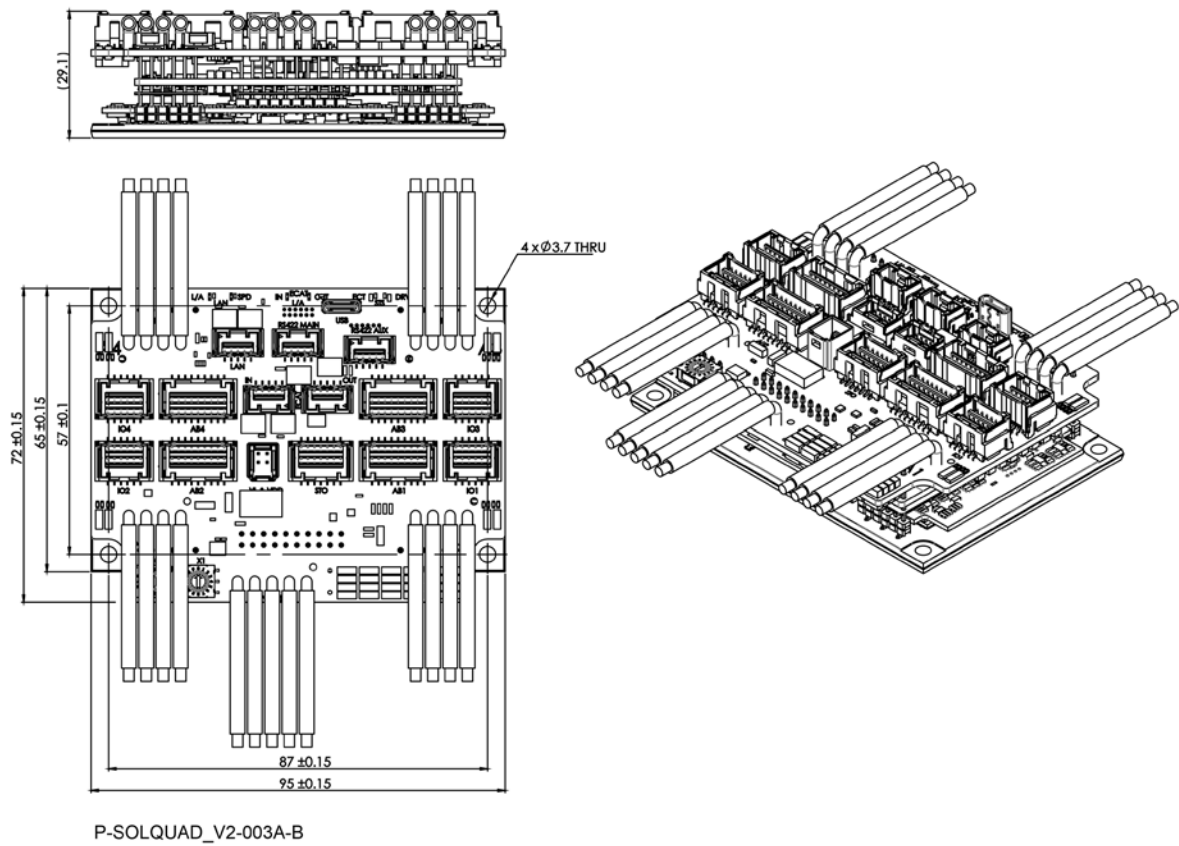


Figure 46: Platinum Solo Bee Quad with Power and Motor Wires

Go Safer, Smarter, Smaller, Simpler.
Go Platinum.

Platinum 
by **Elmo**

www.elmcmc.com